

VICTORIAN CAMBRIDGE

9HB

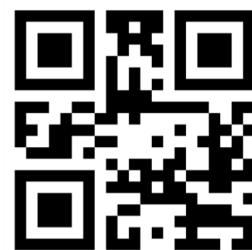

CAMBRIDGE PORCH HB Instruction Manual

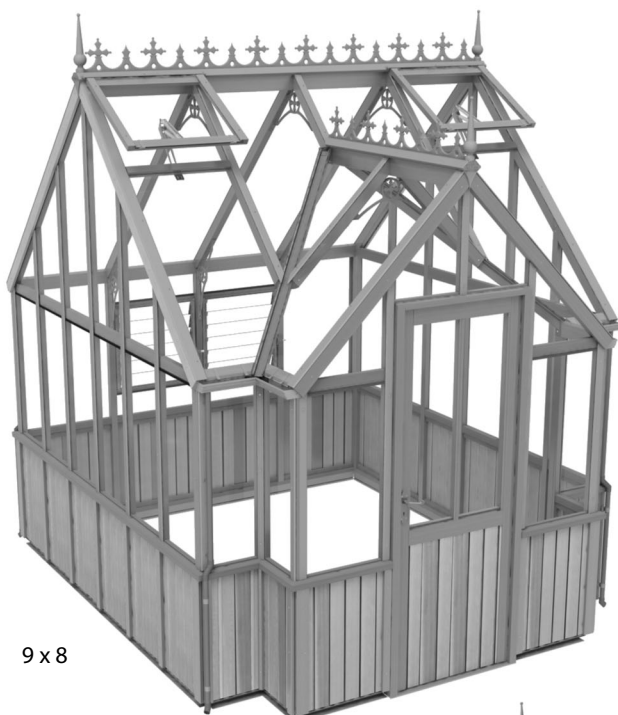

9 x 8



Made in the United Kingdom

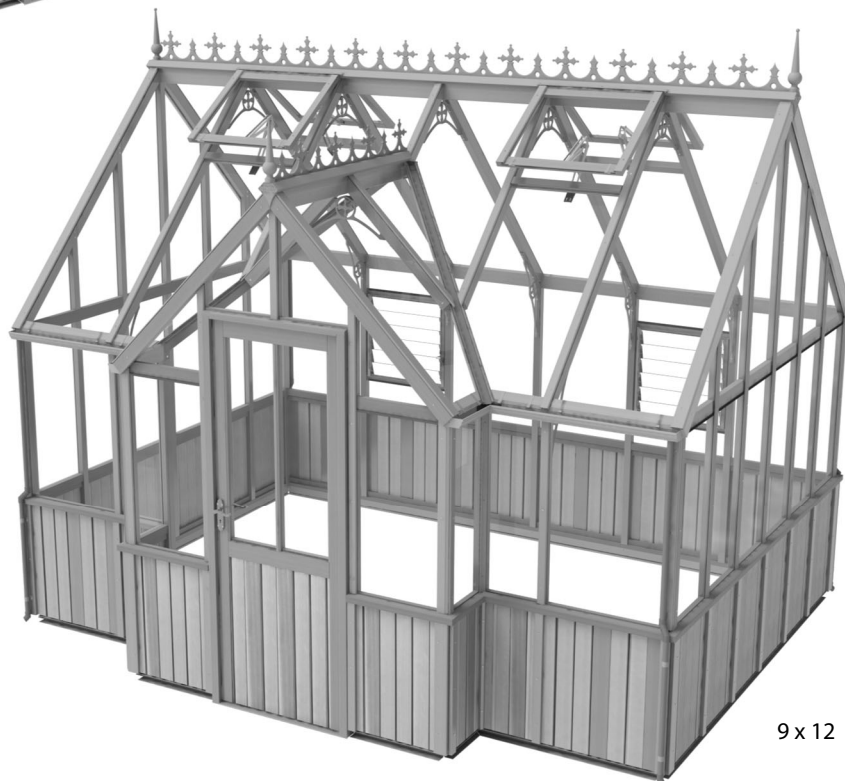

9 x 12

Please read all instructions before proceeding

06/26



9' Wide Victorian HB Cedar Greenhouse Assembly Instructions

Contents:	Section	Page
Introduction	-	3
Base Preparation / Dimensions	1	4-5
Overview	2	6-7
Base Assembly	3	8
Rear Assembly	4	9-10
End Gable Assembly	5	11-15
Porch Assembly	6	16-21
Frame Assembly	7	22-25
Door Assembly	8	26-28
Roof Assembly	9	29-35
Mid Rail Assembly	10	36-38
Half Board Installation	11	39-40
Louvre Installation	12	41
Glazing (part 1)	13	42-46
Gutter and Downpipe Installation	14	46-49
Glazing (part 2)	15	50-52
Roof Vent Installation	16	53-55
Optional Cresting	17	56
End Caps and Finials	18	57
Finish Installation	19	58
Optional Auto Louvre Installation	20	59-60
Parts Lists		61-64

Introduction

Thank you for purchasing your new Alton greenhouse. We recommend you familiarise yourself with the instructions and read all safety information before you commence assembly. This instruction manual is also available online at www.greenhousepeople.co.uk in the technical help section should you need to reprint it. Should you require any additional advice you can always call us on 01782 385409.

Safety Warning

- Glass, aluminium and timber can potentially cause injury. Please ensure you wear protective goggles, gloves, headgear and suitable footwear when assembling and glazing the building.
- Please remember that glass is fragile and should be handled with extreme care. Always clear up and dispose of any breakages immediately.
- Do not assemble the greenhouse in high winds.
- For safety reasons and ease of assembly, we recommend that this greenhouse is assembled by a minimum of two people.
- Please clear all lying snow from the greenhouse roof as it can cause the roof to buckle or collapse.

Site Preparation

- When selecting a site for your greenhouse, it is vital that you choose as flat and level an area as possible.
- A concrete or slabbed base will provide the most solid foundation for your greenhouse. A slabbed base would be our preferred choice as this helps with drainage.
- Avoid placing your greenhouse under trees or in other vulnerable locations.
- To minimise the risk of wind damage, try to select as sheltered a site as possible, e.g. beside a hedgerow or garden fence.

Additional Considerations

- Please bear in mind that assembling your greenhouse can be time consuming. You may need to spread the construction over two or more days. We recommend that you avoid leaving the building partially glazed. If you ever have to leave your greenhouse half assembled and not anchored down, weigh it down with slabs or bags of sand to stop the wind moving it.
- You will find it helpful to prepare a large, clean and clear area in which to work in. A garage floor or flat lawn area is ideal.
- If you have arranged for someone to install your greenhouse for you, please check that all components are included. Most parts are numbered and can be identified by a stamp or removable label. Alternatively, the components can be identified by lengths detailed in the packing list in your main cardboard box / back of manual.
- Remember this is a natural timber product, the wood may soak up some water and some staining may occur. Your Evolution greenhouse is factory dipped in a clear spirit based preservative. We recommend that you re-apply some clear treatment annually particularly on the most exposed areas. If you want to avoid this and give your greenhouse a more permanent finish you could apply an oil based product (refer to manufacturers recommendations for recoating).

Base Preparation

It is necessary to leave sufficient working room around your greenhouse when you're putting it up and also to allow for the possible need to replace a piece of glass in the future. If possible try to leave a space of 2ft/610mm around the greenhouse.

Locate the greenhouse where there is maximum amount of sunlight and avoid if possible any shade from trees, fences or other buildings. Over-hanging branches can be a particular nuisance and should be avoided.

Choose a site where the greenhouse is relatively easy to get to and convenient to bring water to and possibly a supply of electricity.

Finally, and most importantly, choose a site where your Alton Greenhouse will look right so that it will complement your garden.

We cannot emphasize how important it is to have a proper base for your Alton Greenhouse to be erected upon. It is essential that the **BASE IS FLAT, LEVEL AND SQUARE AS WELL AS BEING SUBSTANTIAL** enough to take the weight of the greenhouse including its 3mm glass. A slabbed base which is larger than the greenhouse is the ideal solution. The gaps between the slabs allow for any water which may enter the building to percolate away easily.

Note that the door opens inwards so you should not have any higher ground or obstacles inside the arc of the front door.

IMPORTANT: Do not anchor your greenhouse down until it is fully assembled including glazing unless you are 100% sure your base is square and level. If not your glass will not fit properly.

Base Dimensions

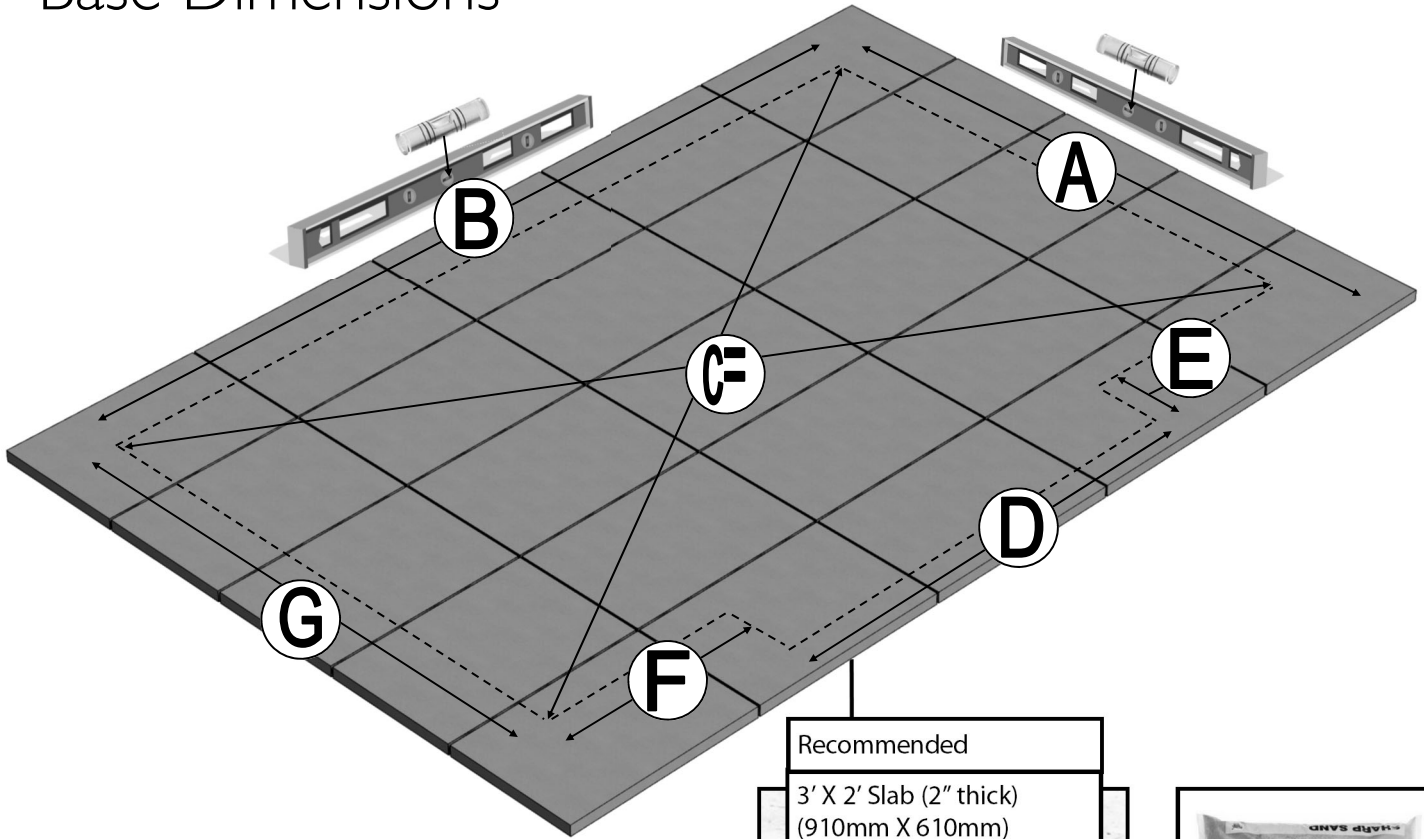

Slab Base Size (Recommended)

Note: The base should always be larger than your building.

Note: If a membrane is used this may hinder drainage.

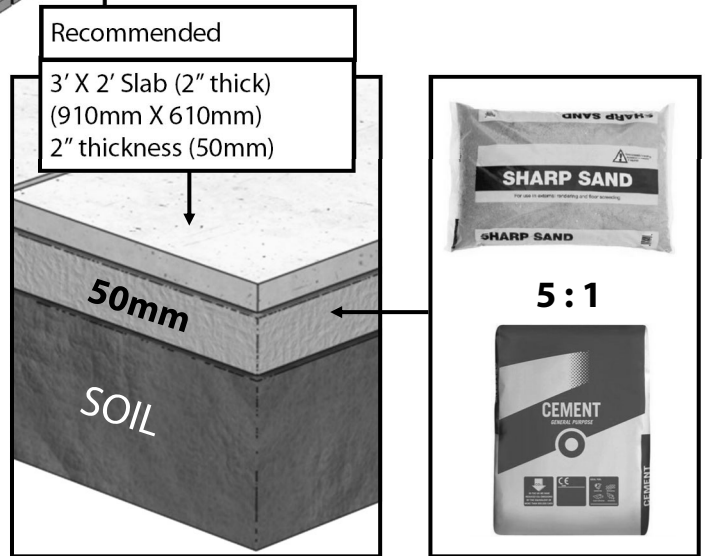

EXTERNAL GREENHOUSE DIMENSIONS (mm)

Model sizes listed are **nominal**, use 'mm' measurements.
i.e.: an 9 x 16 is the model 9'11" x 16'9"

MODEL		A (mm) TOTAL WIDTH	B (mm) LENGTH	C (mm) DIAG	D (mm) PORCH	E (mm) PORCH DEPTH	F (mm) RETURN LENGTH	G (mm) WIDTH
VICTORIAN (9)	9 x 8	3007	2566	3689	1902	357	332	2650
	9 x 12		3827	4655			962.5	
CAMBRIDGE (HB)	9 x 16		5087	5736			1592.5	
	9 x 20		6347	6878			2222.5	
	9 x 24		7607	8055			2852.5	
	9 x 28		8867	9254.5			3482.5	

Overview

To build your new greenhouse you will need the following tools:

- | | |
|----------------------|--|
| Spirit Level | Pencil |
| PZ2 Screwdriver Bit | Cordless Screwdriver (2 would be ideal, 1 to drill and 1 to screw) |
| 4mm Drill Bit | 7mm Masonry Bit |
| Hammer Drill | Hammer |
| Wooden/Rubber Mallet | Tall step ladders x 2 |
| Tape Measure | |

There are 9 different types of screws used in the construction of the greenhouse. These are as follows, with examples of where to look out for them:

	EV0329 13mm SELF TAP	EV0328 20mm PAN HEAD	EV0330 25mm CSK HEAD	EV0331 25mm PAN HEAD	EV0332 40mm PAN HEAD	EV0333 50mm CSK HEAD	EV0367 50mm PAN HEAD	EV0334 80mm CSK HEAD	EV0339 100mm CSK HEAD
	Fixes the vent hinge to the ridge cover cap.	Used on roof vents.	Transit screws and on roof vents and door.	Fixes all capping and metal-work.	Secures Timber Cladding.	Fixes glazing bars to ridge and cills.	Used on upper porch casting.	Secures corner joints and the roof glazing bars to the ridge.	Fixes the roof glazing bars to the eaves and side glazing bars in one go.
BUILDING SIZE	QUANTITY								
9x8	6	16	66	244	129	42	11	50	9
9x12	12	32	74	296	165	46	11	58	13

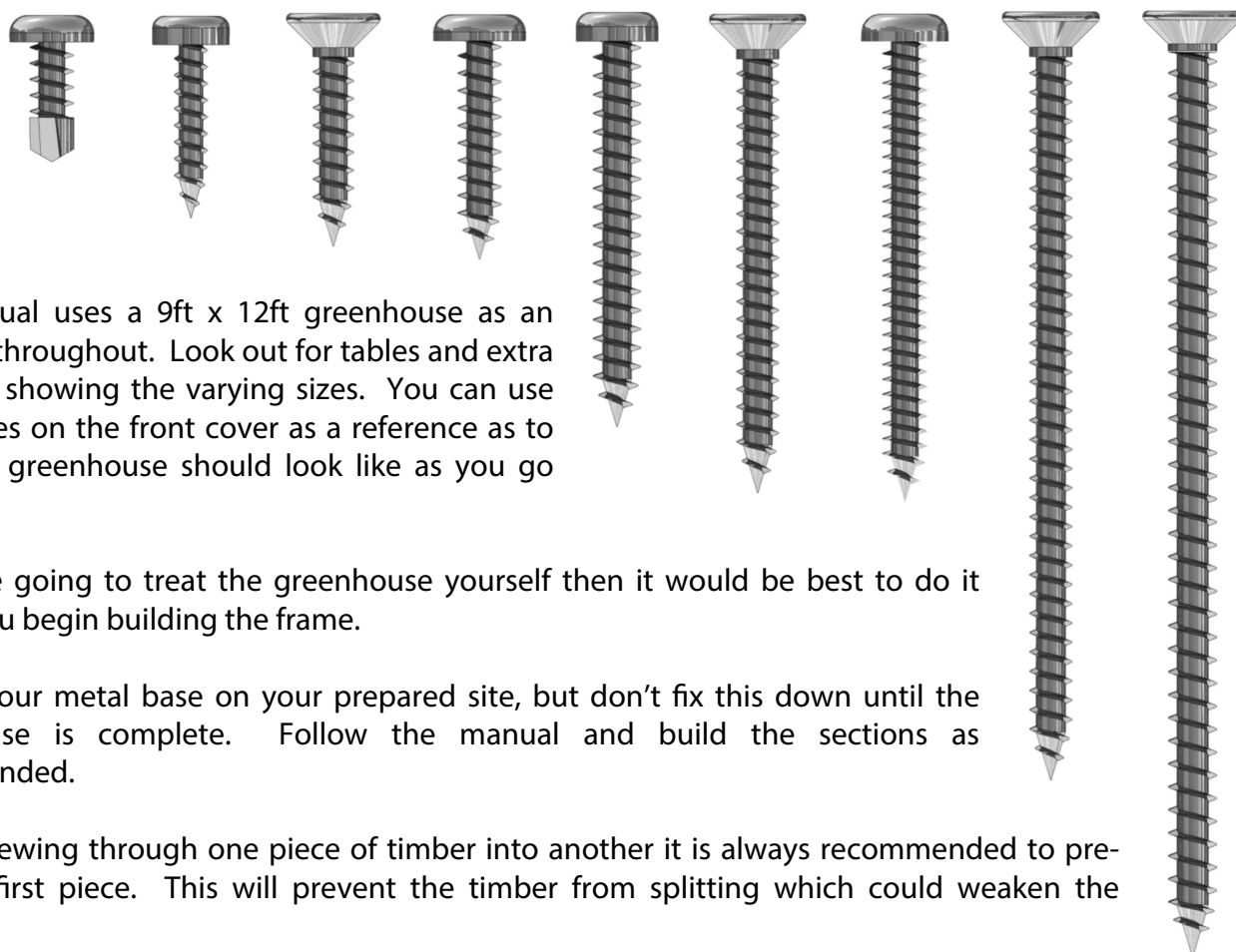

This manual uses a 9ft x 12ft greenhouse as an example throughout. Look out for tables and extra diagrams showing the varying sizes. You can use the images on the front cover as a reference as to what the greenhouse should look like as you go along.

If you are going to treat the greenhouse yourself then it would be best to do it before you begin building the frame.

Set out your metal base on your prepared site, but don't fix this down until the greenhouse is complete. Follow the manual and build the sections as recommended.

When screwing through one piece of timber into another it is always recommended to pre-drill the first piece. This will prevent the timber from splitting which could weaken the structure.

Overview

You can build the sides and gables flat on the ground and then with help or using a prop position the first one ready for installation. You then work your way around the greenhouse connecting each section. Once you have completed the gables and sides you can install the ridge and the roof.

Glazing the structure is very simple but be very careful of the edges of the glass as the panes will break into tiny peaces if you catch an edge on a hard surface such as concrete. You should also wear suitable gloves and goggles when handling the glass (this also helps to keep it clean). It is good practice to pre-load the cedar bar capping with screws and position this around the greenhouse ready for you when you arrive with the glass.

During glazing you will also need to fit the louvre vents so make sure you have these built and ready to slot in. These fit between 2 pieces of glass and are held in place by the capping system.

Now that the sides are glazed the gutters and downpipes need to be installed **before** the majority of the roof glass otherwise the roof sheets impede their attachment, think about where you might site a water butt when doing this.

Once the roof is glazed fit the roof vents. This is done from the inside, gain access through the opening on a set of steps.

Longer Models

If your building is longer than 12' i.e. has extensions then please also refer to the separate extension manual before you begin construction. Extensions are available in 4' and 8' nominal lengths which can go each side of either an 8' or a 12' central core.

A 16' building for example is comprised of a 8' core with a 4' extension either side of it, i.e. end gable + 4' extension + 8' core + 4' extension + end gable.

A 28' model for example is comprised of a 12' core with a 8' extension either side of it, i.e. end gable + 8' extension + 12' core + 8' extension + end gable.

Option of gluing joints. This is not required for strength but you may do it if you wish. However bear in mind if you ever intend to move or adapt the greenhouse in the future this would make it very difficult. The best glue for this would be Poly Urethane Wood Adhesive. Take care when applying this, you only need a very small amount as the glue expands to fill the joint. If you use too much it may seep out of the joint and could be unsightly! Try a test piece before you start.

Read through the rest of this manual before starting, you are less likely to miss something doing this and you will have a better understanding of how it all works.

Base Assembly

Lay out your aluminium base sections as the diagram shows. Use the twist-in crop head bolts in the bolt channels for attaching the base brackets (D174M), diagram 1. The base brackets should always be positioned either side of the door, in the corners, in the middle of the end gables and equally spaced down the side. Use the joining brackets (EV0311M) in each corner with a standard bolt to join the sections (diagram 1). The top holes will take a 25mm screw when the side cills are fixed to it later. Look for the length of building you have in the tables below to check what you should be using.

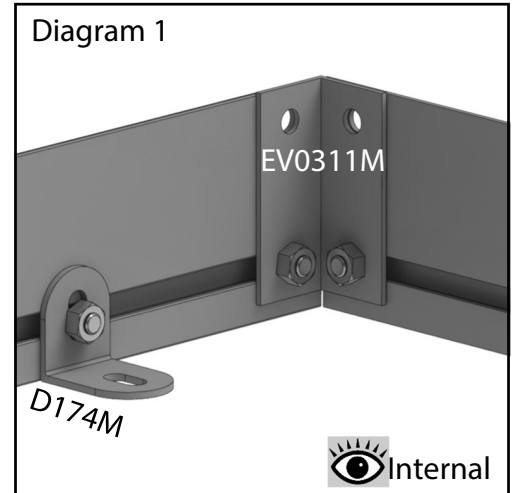

NB. For Extensions refer to separate manual.

4' base extension = EV1173M (1262mm), 8' base extension = EV0307M (2520mm)

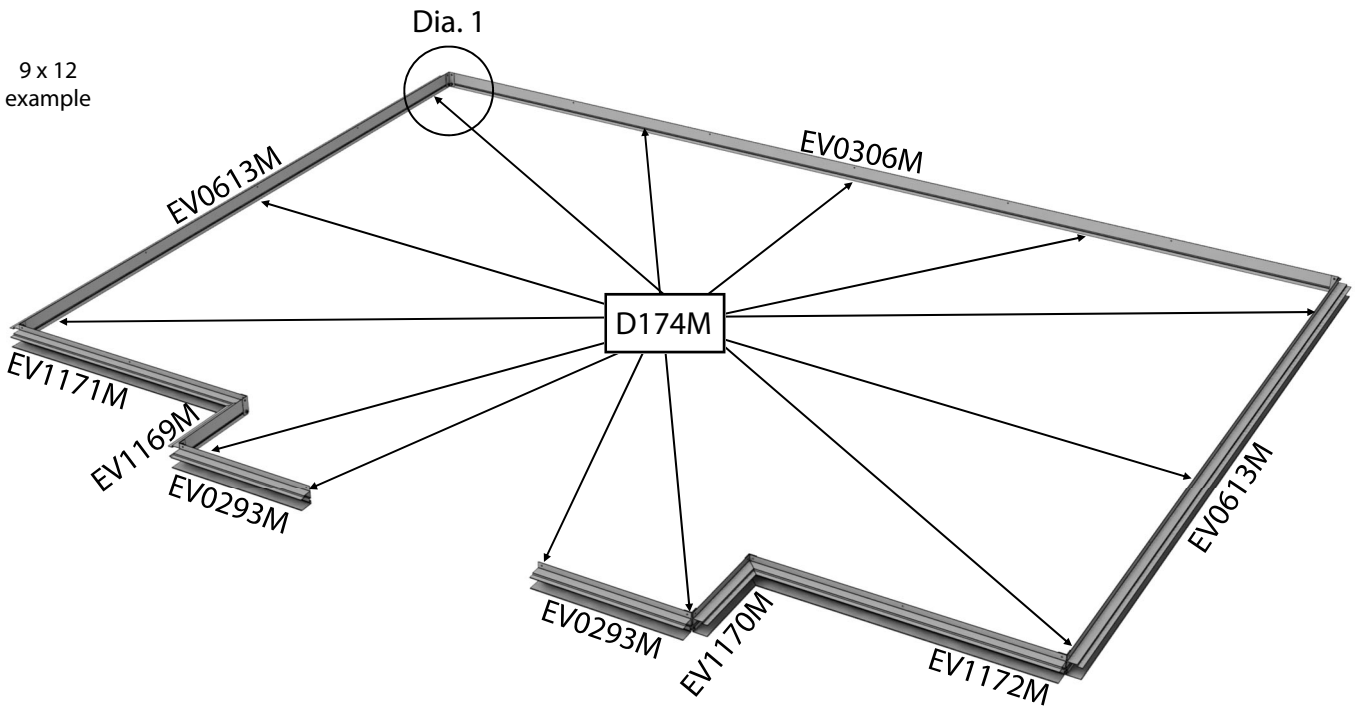

9 x 12 example

9x 12 Model (shown)			
Part Name	Part Number	Size (mm)	Qty
Porch Front	EV0293M	497	2
Porch Short LH	EV1169M	330	1
Porch Short RH	EV1170M	330	1
Porch Long LH	EV1171M	960	1
Porch Long RH	EV1172M	960	1
End Gable	EV0613M	2554	2
Side Base 12	EV306M	3731	1
Joining Bracket	EV0311M	-	8
Base Bracket	D174M	-	13

9 x 8 Model			
Part Name	Part Number	Size (mm)	Qty
Porch Front	EV0293M	497	2
Porch Short LH	EV1169M	330	2
Porch Short RH	EV1170M	330	2
End Gable	EV0613M	2554	2
Side Base 8	EV0304M	2471	1
Joining Bracket	EV0311M	-	8
Base Bracket	D174M	-	12

Rear Assembly

To start building your greenhouse begin by laying out the components for your side flat on the ground like the diagram below. Use the tables below to identify your building length and the components with the part numbers and sizes.

First of all drill pilot holes through the bottom of each mortise on the cill section (e.g.EV0018) (diagram 2, page 10). Then slot each glazing bar into the mortise holes. These are designed as a tight fit so you may need help with this or maybe use a solid object to push against. Once firmly in position fix with 50mm CSK screws (EV0333). Now slot the eaves rail into position (e.g. EV0421). There is no need to fix this yet as it is done at a later stage.

9 x 12
example

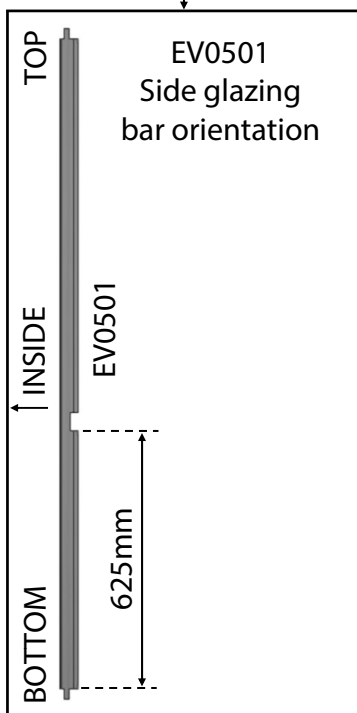
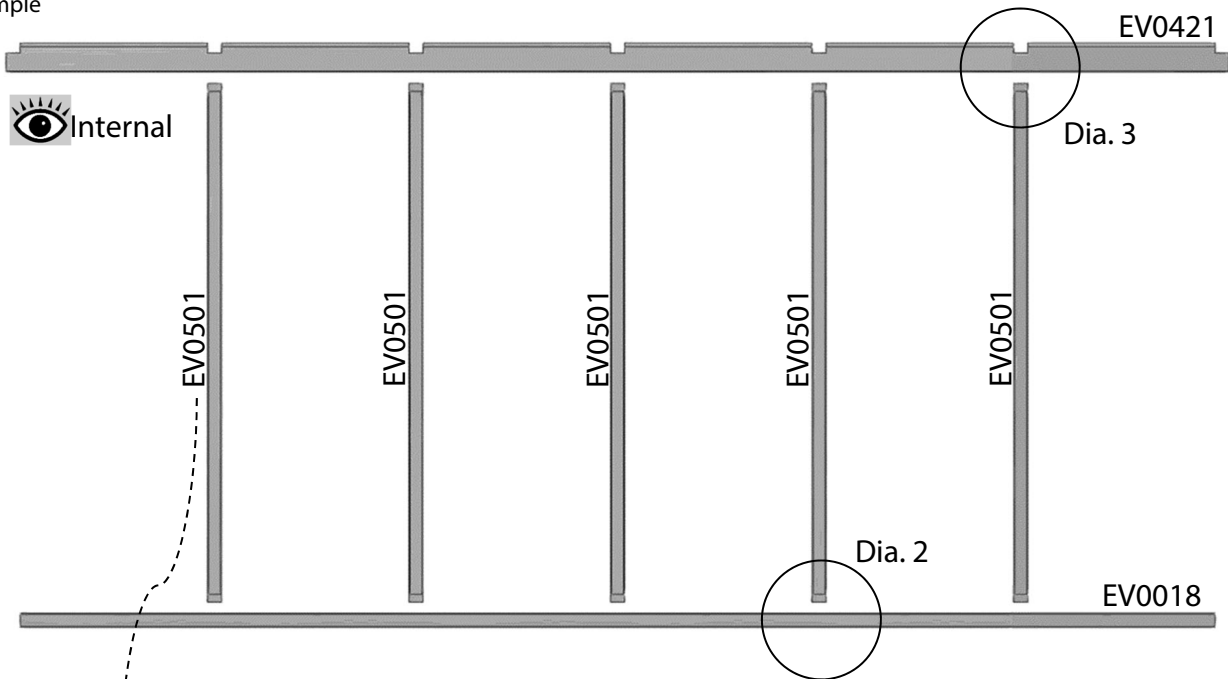

Side 8			
Part Name	Part Number	Size (mm)	Qty
Cill	EV0016	2476	1
Eaves Bar	EV0419	2564	1
Glazing Bar	EV0501	1624	3

Side 12 (shown)			
Part Name	Part Number	Size (mm)	Qty
Cill	EV0018	3736	1
Eaves Bar	EV0421	3824	1
Glazing Bar	EV0501	1624	5

Rear Assembly

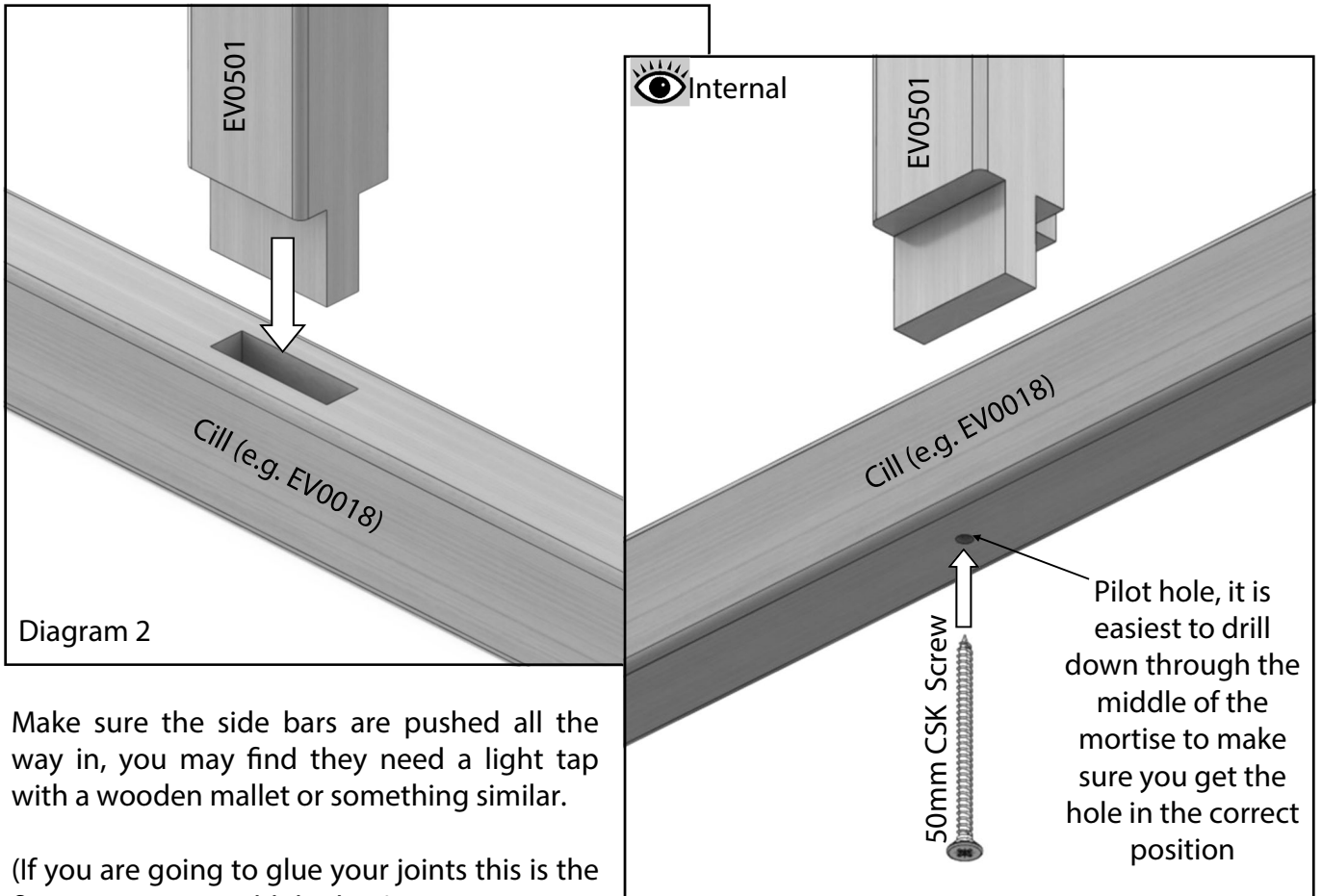

Make sure the side bars are pushed all the way in, you may find they need a light tap with a wooden mallet or something similar.

(If you are going to glue your joints this is the first point you would do this.)

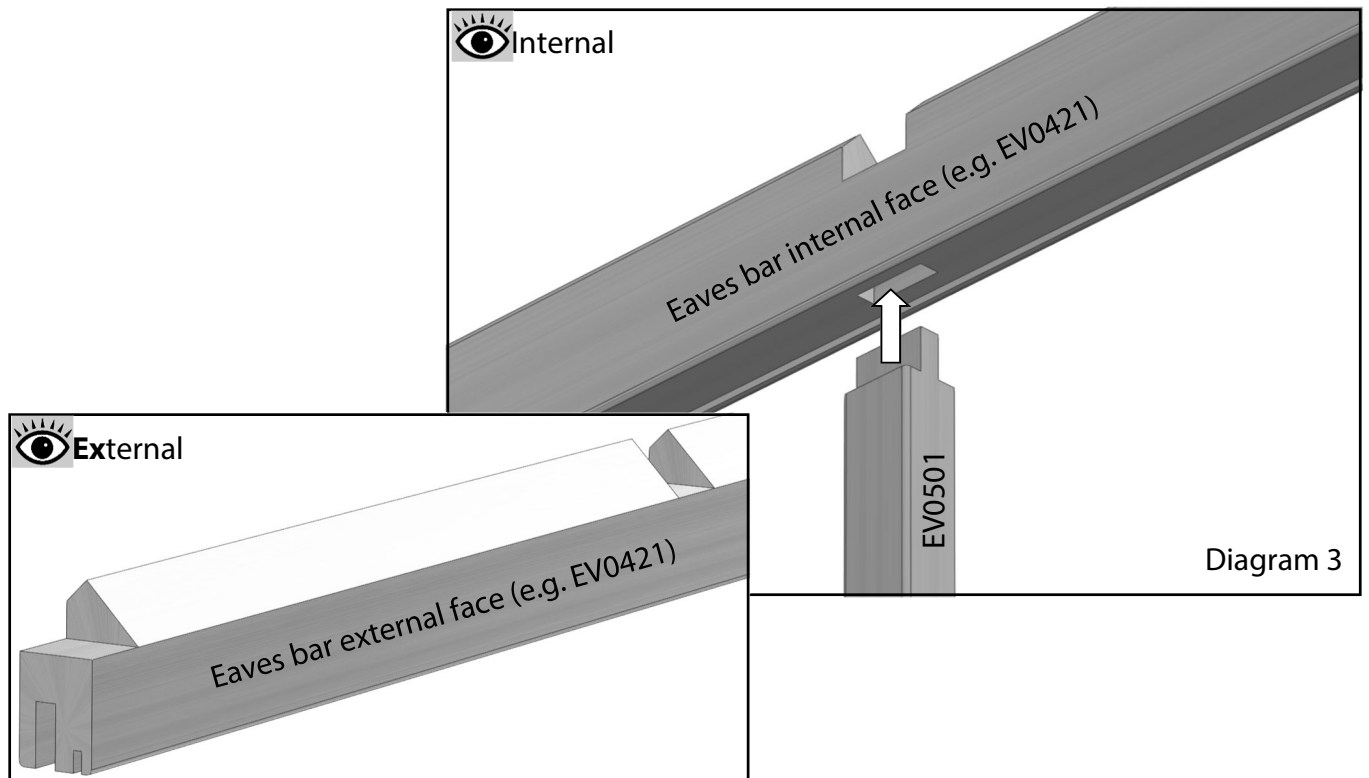

End Gable Assembly (two required on this model)

8ft End Gable x 1			
Part Name	Part Number	Size (mm)	Qty
Rear Cill	EV0405	2569	1
Roof Corner R	EV0482	1854	1
Roof Corner L	EV0483	1854	1
Side Corner R	EV0502	1650	1
Side Corner L	EV0503	1650	1
Gable Purling R	EV0409	854	1
Gable Purling L	EV0415	854	1
Rear Mid Purling	EV0413	851	1
Standard Bar	EV0501	1624	3
Above Purling R	EV0465	518	1
Above Purling L	EV0466	518	1
Gable Bar R	EV0506	2582	1
Gable Bar L	EV0507	2582	1
Mid Gable Bar	EV0461	1275	1

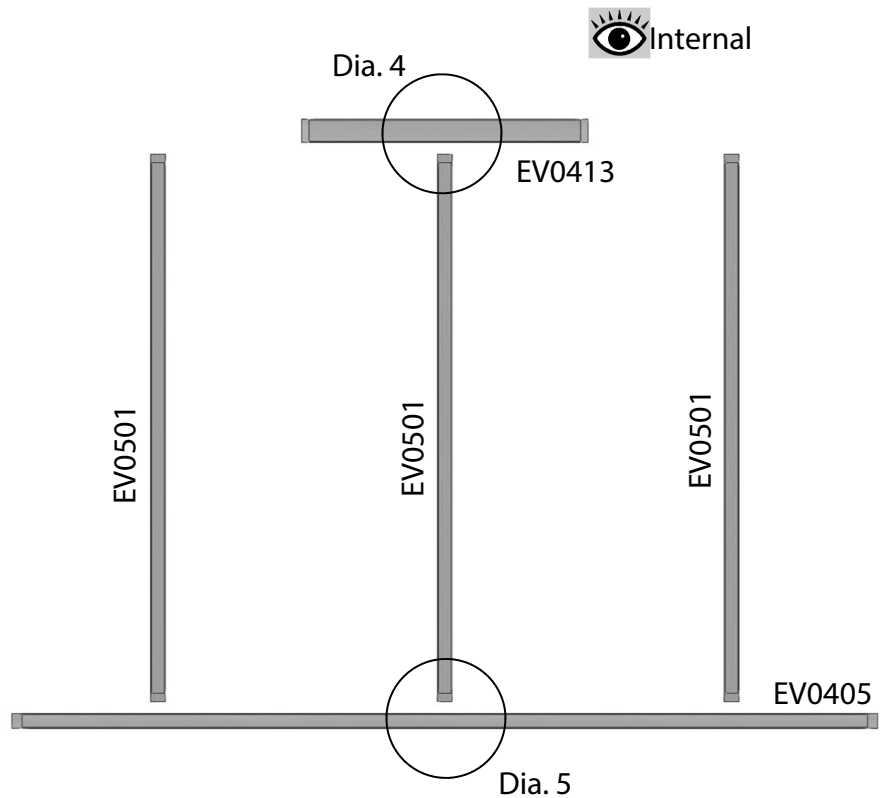

As with the side cill you will need to drill pilot holes in the bottom of the mortise holes (diagram 5).

Assemble the glazing bars (EV0501) with the gable cill flat on the ground as you did with the rear section. These locate in the two outer mortise holes and the middle mortise hole.

Now slot the middle rear purling (EV0413) onto the central glazing bar, this will be fixed shortly (diagram 4).

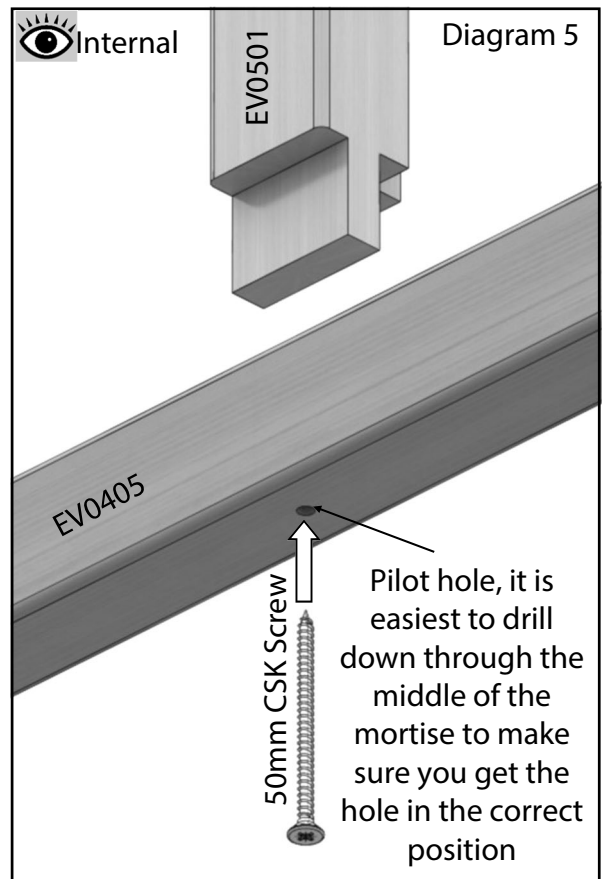
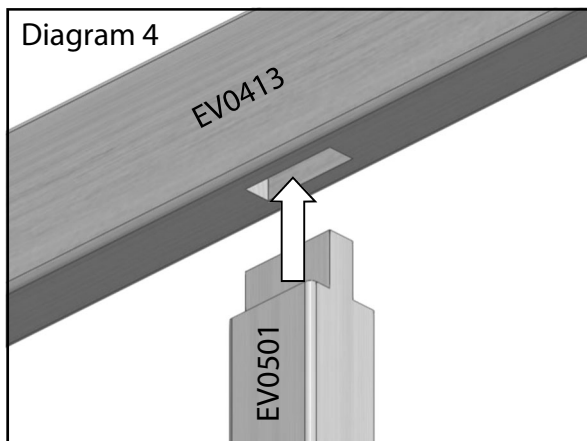

End Gable Assembly

Now slot the two longer gable bars (EV0506 / EV0507) into the cill. These also need to locate with the middle rear purling (diagram 6).

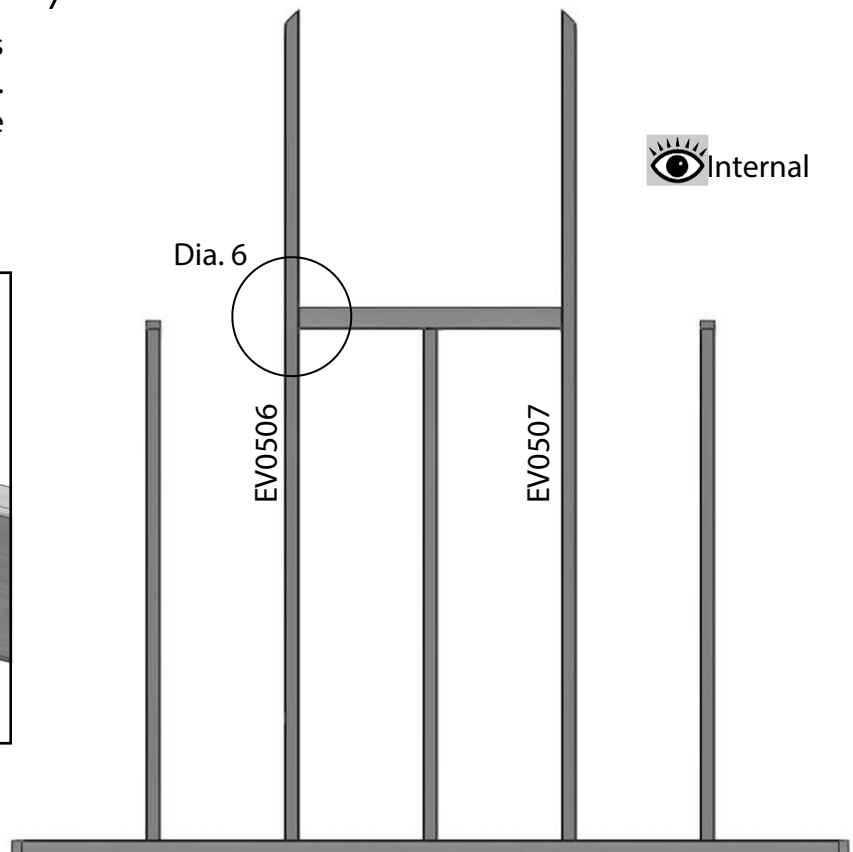
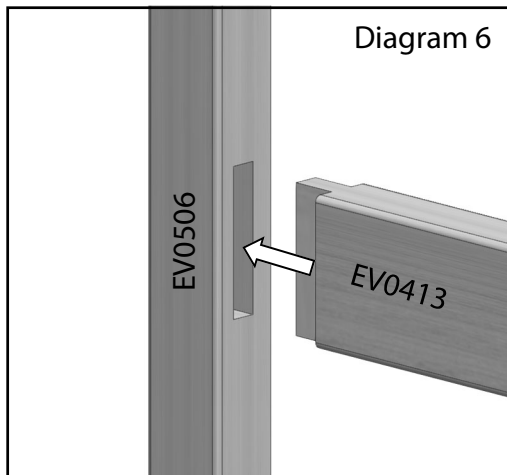

Next fit both left and right purlings to the standard glazing bars (EV0501). These are handed parts and it is important to fit them the correct way round. The purlings will have rounded edges on one side and square cut edges on the other, the rounded edges should be on the inside of the building fitting flush with the other components. The square cut edges should be outward facing and will be set in slightly from the rebate that takes the glass. These simply slot in place for now.

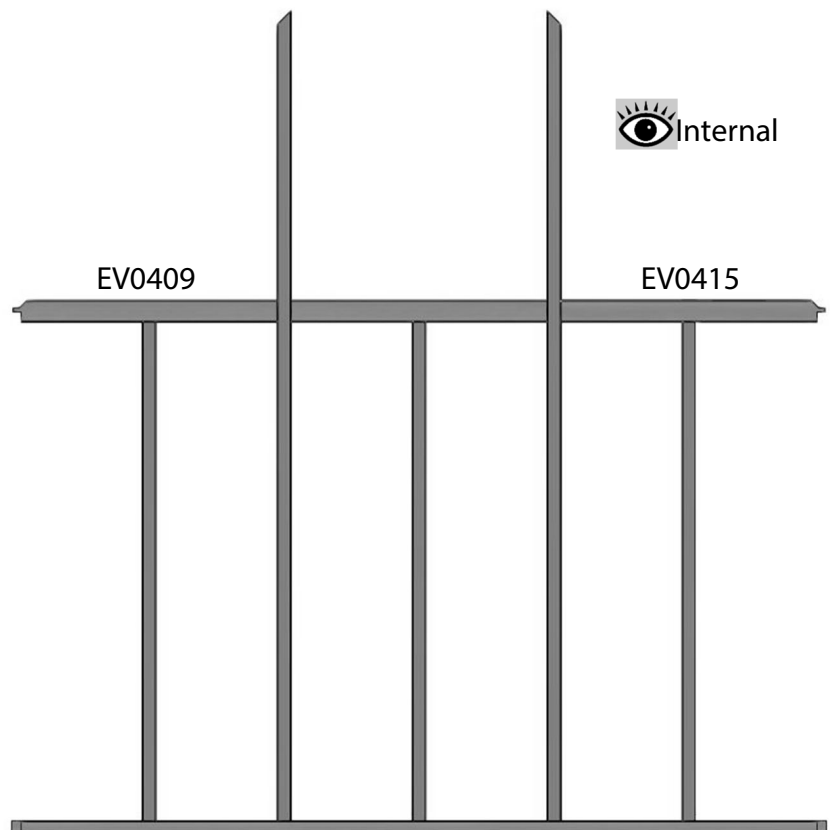

End Gable Assembly

You will need to drill a pilot hole in the bottom of each side corner bar as shown in diagram 7. This should come through half way up the mortise slot. Now slot the side corner bar into place, fix the bottom of the bar with an 80mm CSK screw.

With the top of the bar lined up with the end of the purling (keeping the inside edges flush) drill a pilot hole close to the inside face of the tenon on the purling (diagram 8), then fix with a 25mm countersunk screw. This is only a transit screw so just make sure the joint is nice and tight, a larger fixing will be added later.

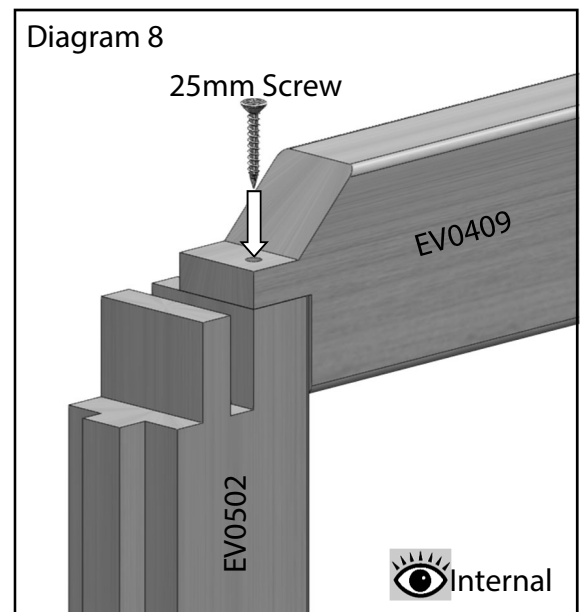
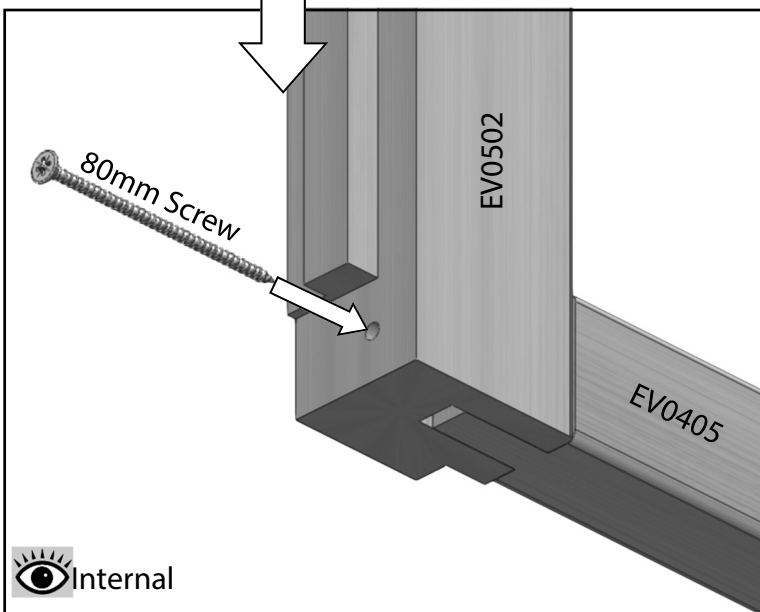
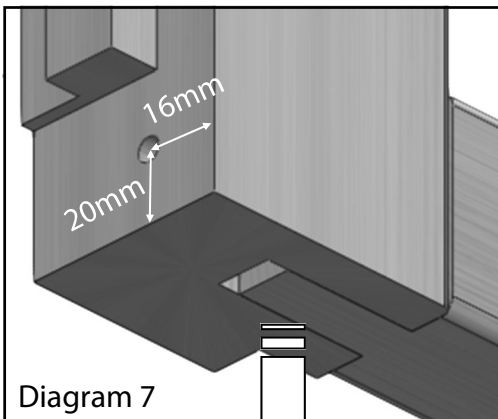
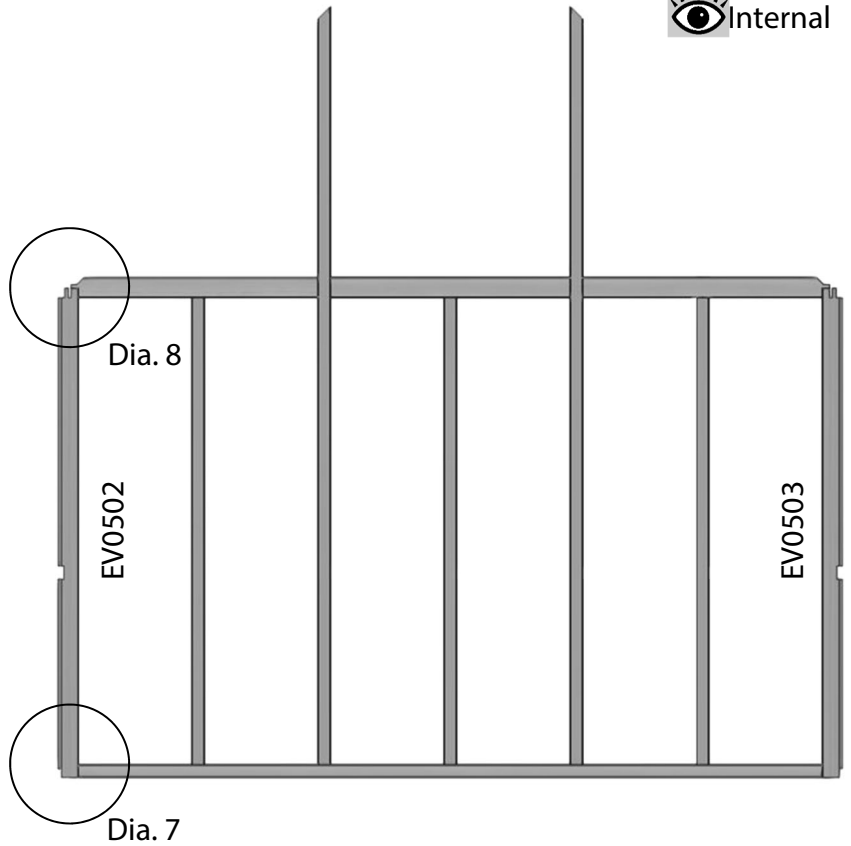

End Gable Assembly

Once the side corner bars are secure slot the above purling glazing bars into place. With all of the gable bars in place drill pilot holes through the lap joints at the end of each bar. The holes should be drilled centrally to the bar and spaced out as shown in diagram 9.

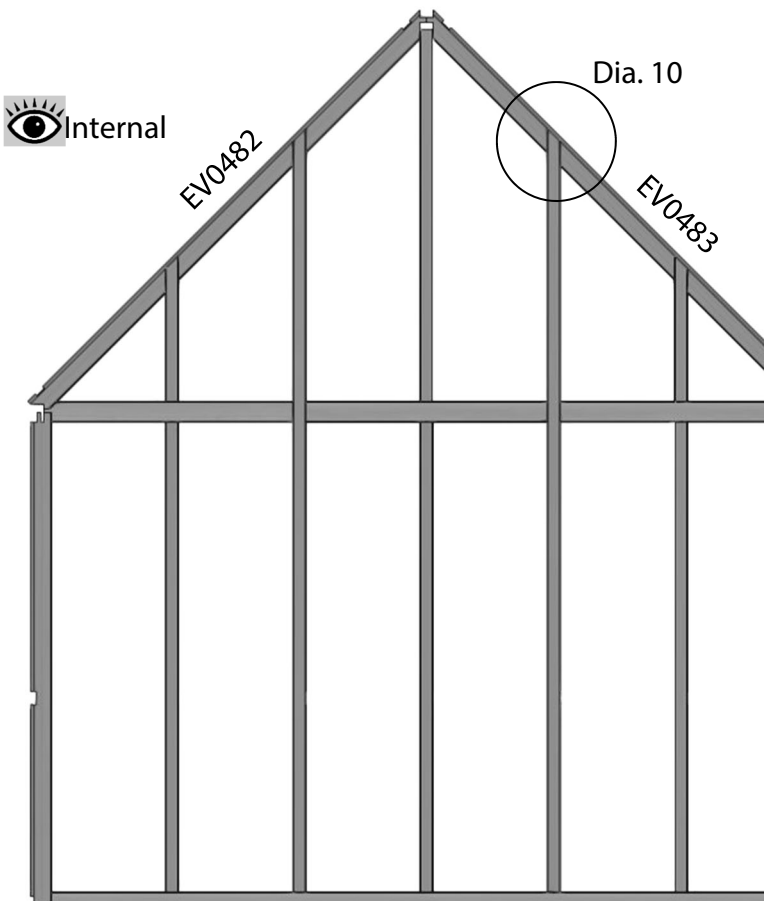
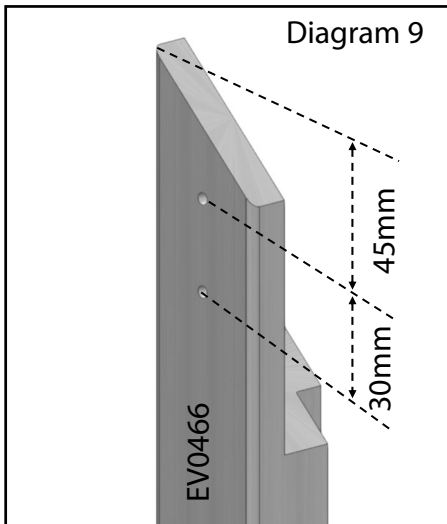
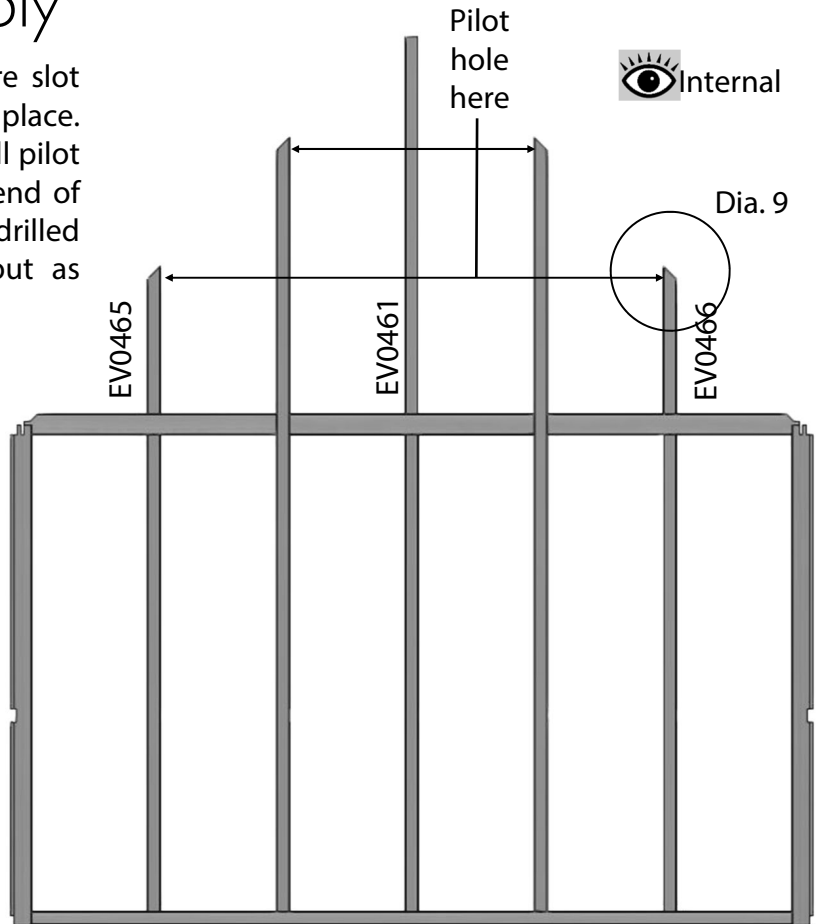

Now slot the two roof corner bars into place, these should be secured with 40mm Pan Head screws (EV0332), diagram 10.

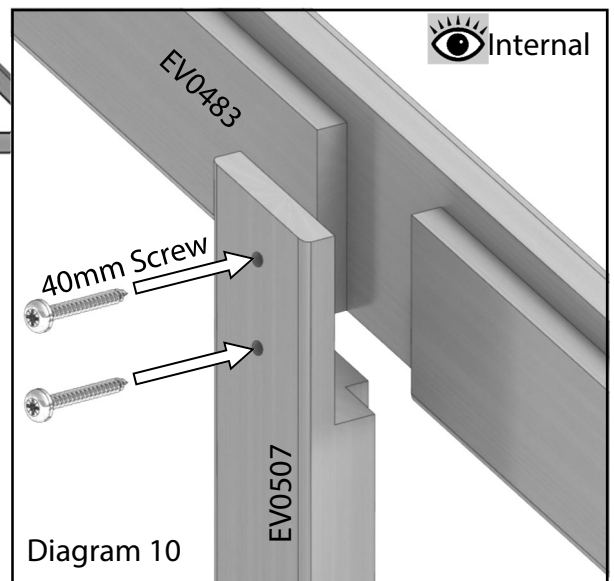

End Gable Assembly

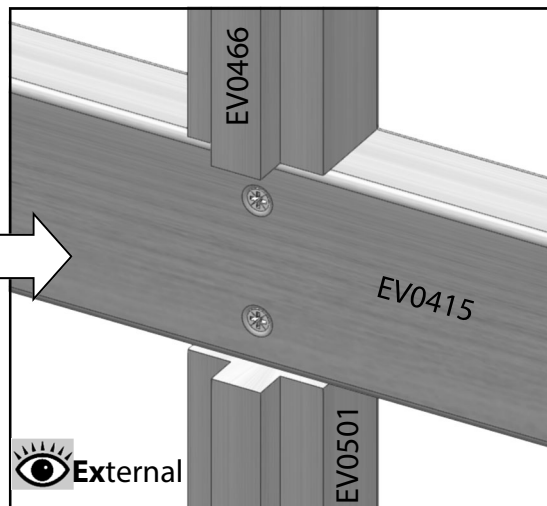
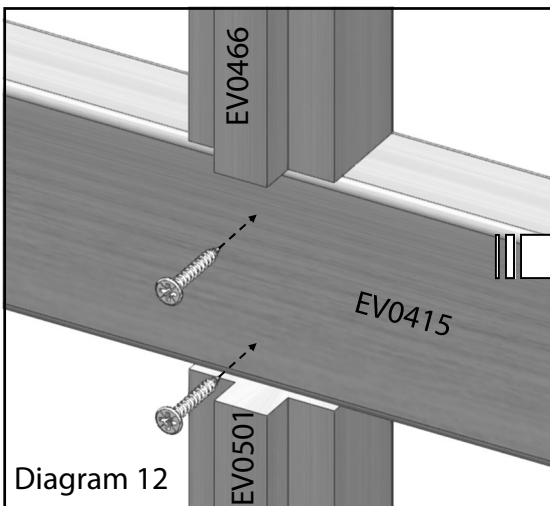
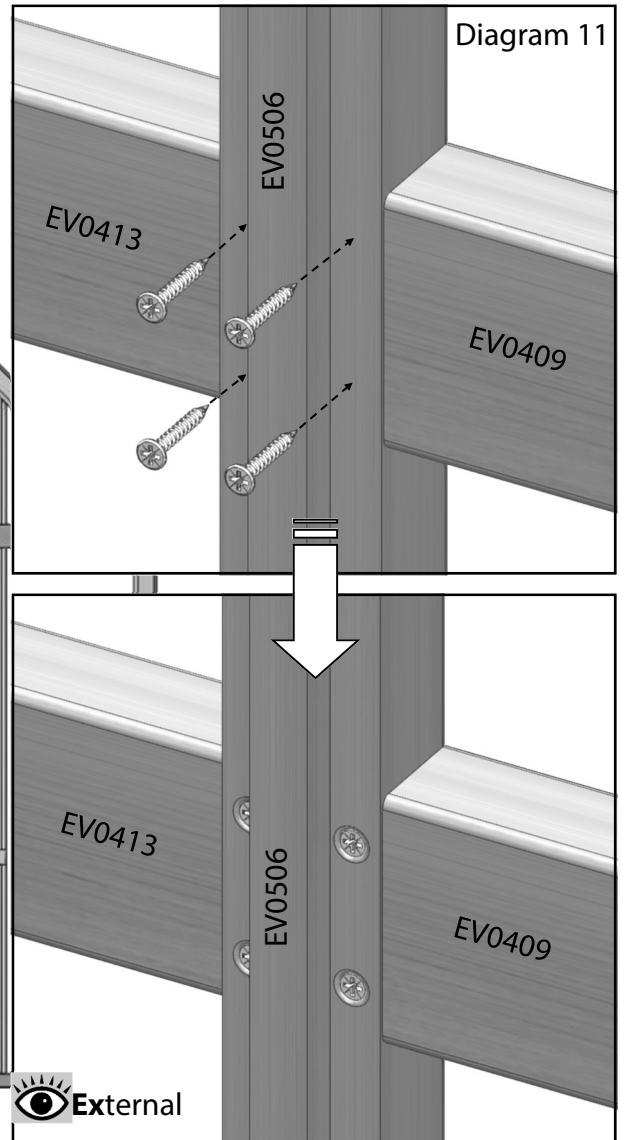
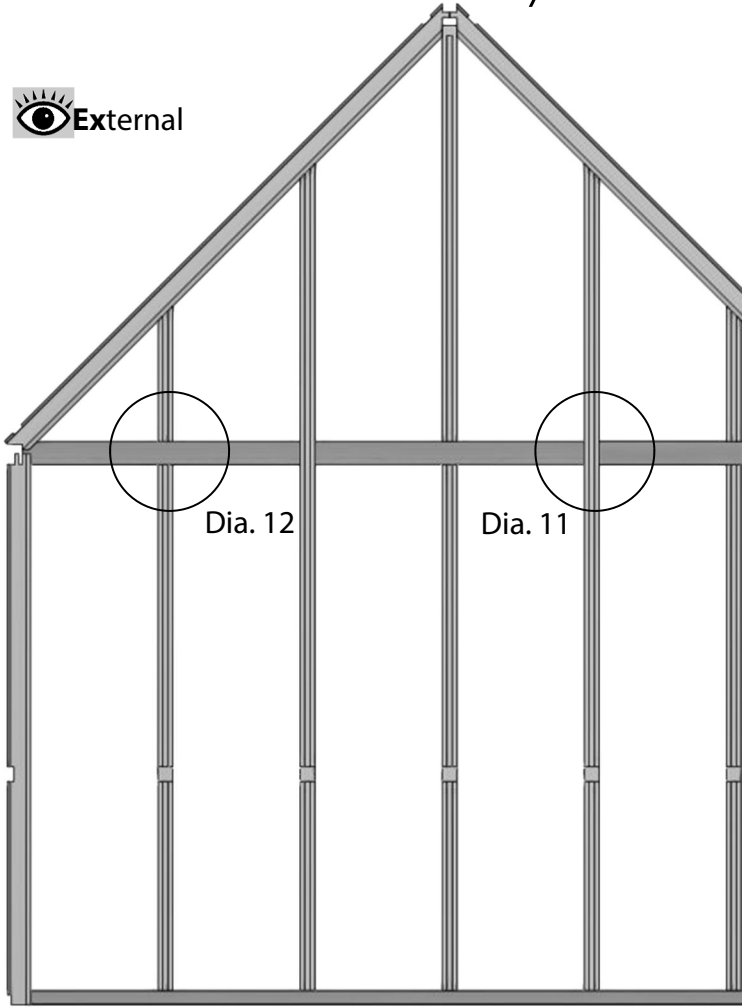

With all the components now in place flip the gable end over so you now have the outside edge facing you. Be careful doing this as some of the parts are not completely supported, it is a good idea to have a helper at this point. Now using 25mm countersunk screws fix the purlings to the glazing bars as shown in diagram 11 and 12. Make sure the head of the screws are below the level of the timber so that they don't have any contact with the glass. Repeat section 5 to create another matching end gable assembly.

Porch Front Assembly

6ft Porch Front			
Part Name	Part Number	Size (mm)	Qty
Front Cill	EV0005	507	2
Roof Corner R	EV0480	1324	1
Roof Corner L	EV0481	1324	1
Side Corner R	EV0502	1650	1
Side Corner L	EV0503	1650	1
Gable Purling R	EV0408	480	1
Gable Purling L	EV0414	480	1
Gable Bar R	EV0504	2208	1
Gable Bar L	EV0505	2208	1
Above door	EV0471	561	1

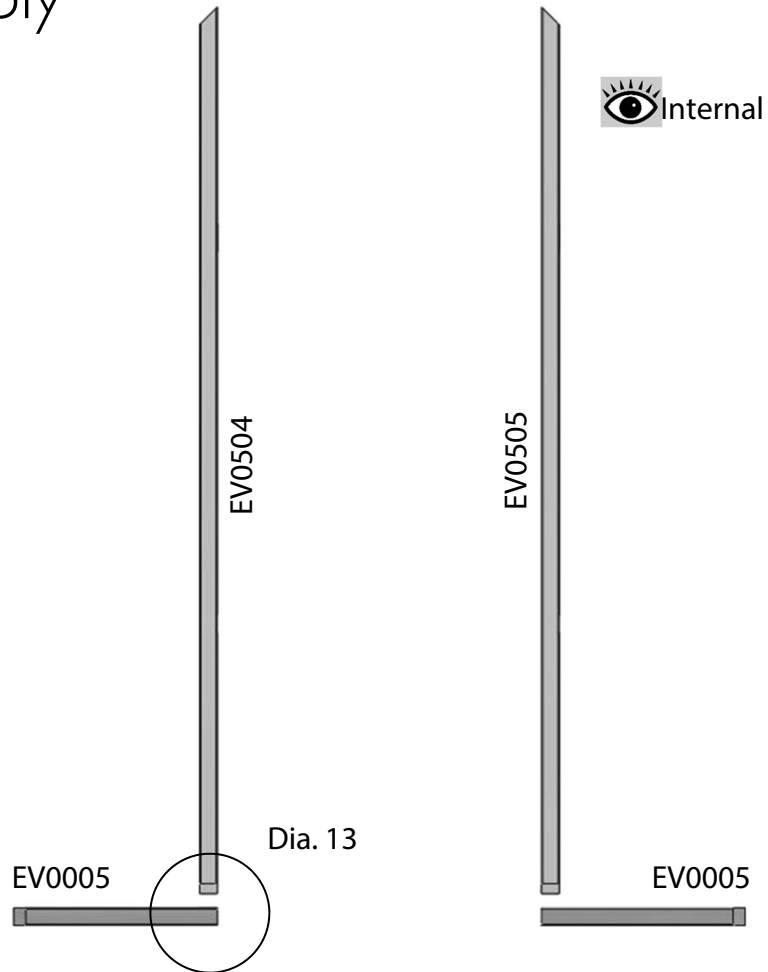

The porch front gable is made slightly differently to the ends as it is in two halves. It is a good idea to build these side by side to make sure you are fitting the parts in the correct orientation.

As before start by fixing the gable bars to the cills shown in diagrams 13 and 14.

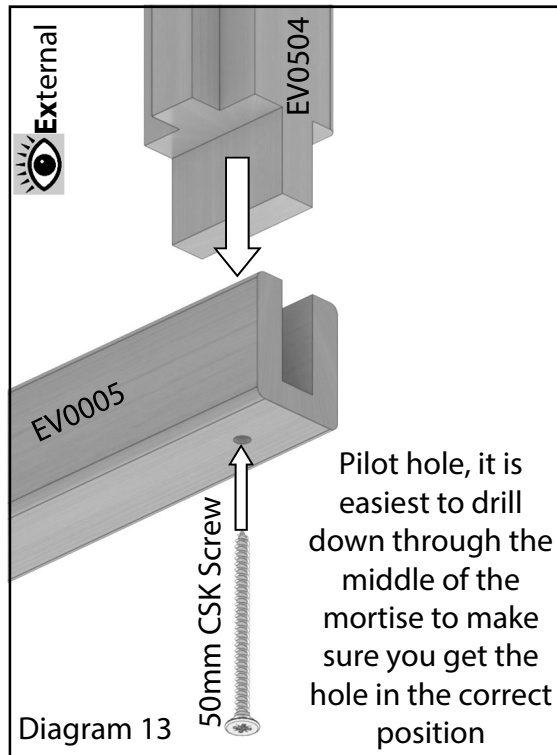

Porch Front Assembly

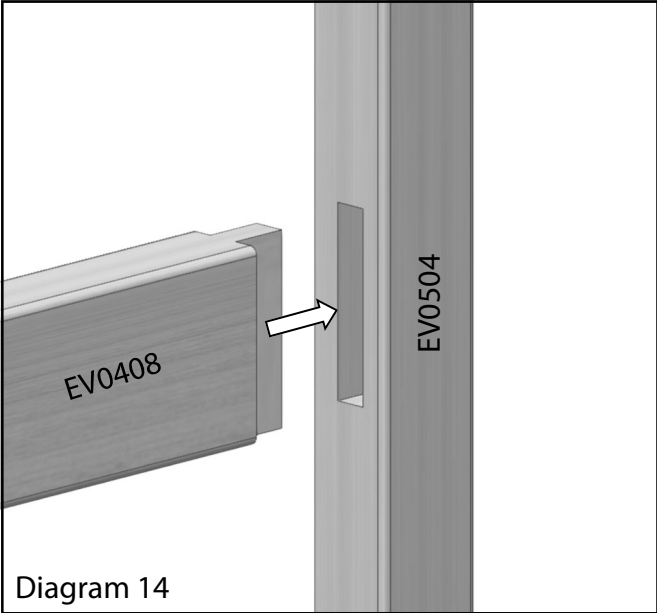
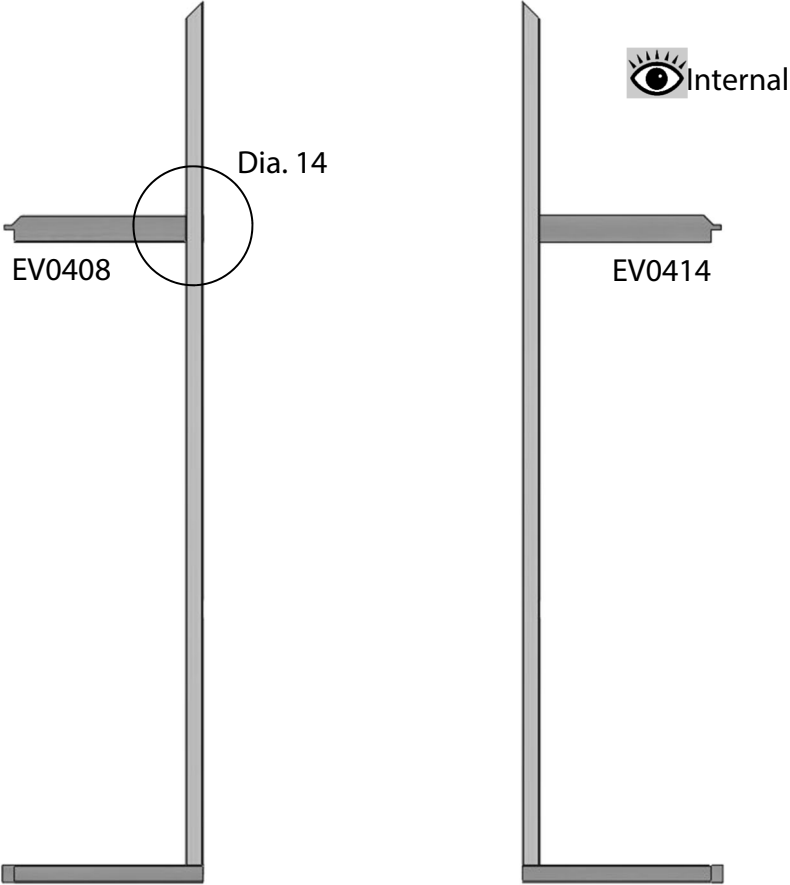

Now slot the purling bars into place, again as with the end assemblies these will be fixed later.

Porch Front Assembly

Drill the pilot holes again as diagram 15 shows. Fix the cill to the corner bar with an 80mm CSK screw.

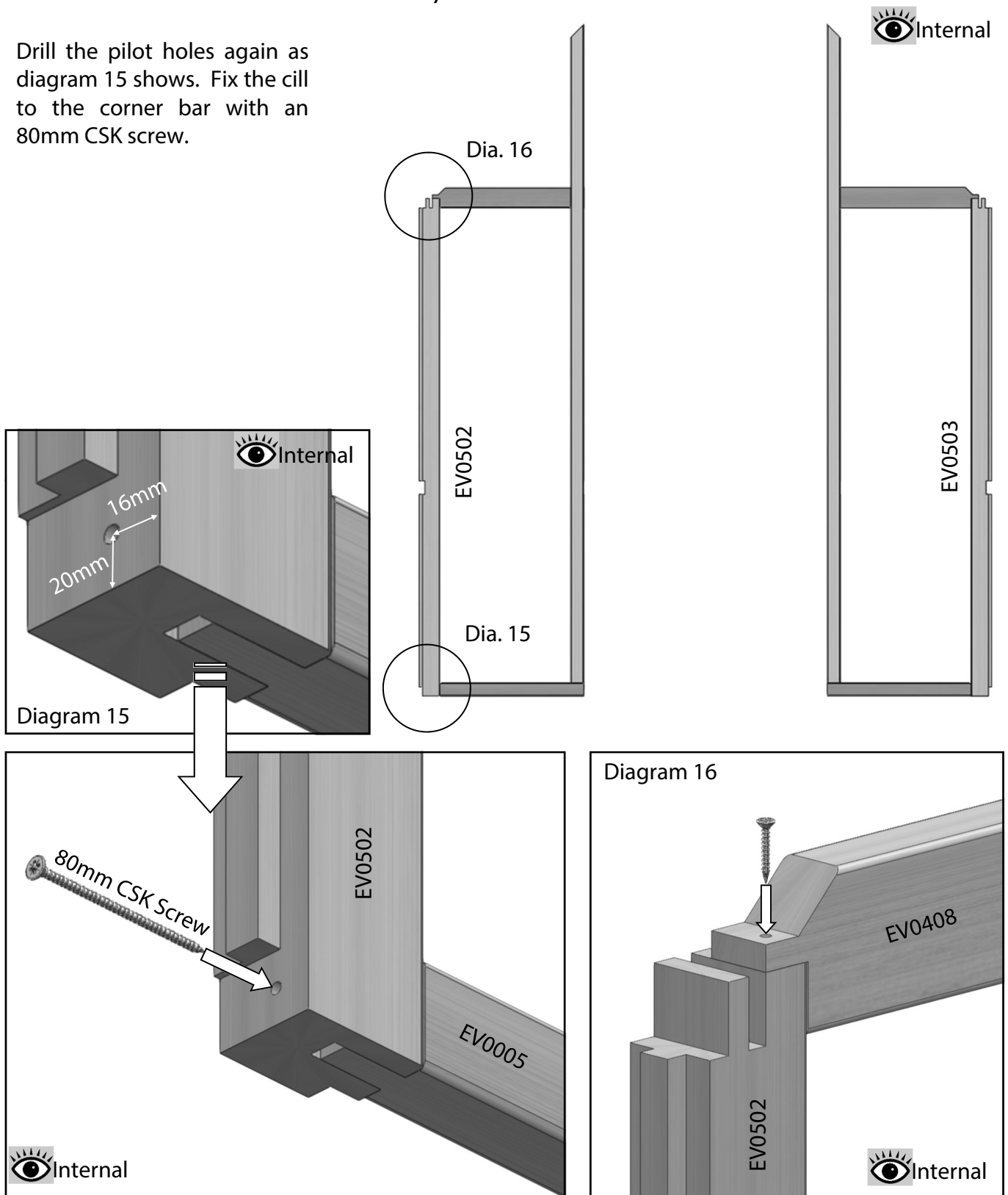

As before (keeping the inside edges flush) drill a pilot hole close to the inside face of the purlings tenon (diagram 16), then fix with a 25mm countersunk screw. This is only a transit screw so just make sure the joint is nice and tight, a larger fixing will be added later.

Porch Front Assembly

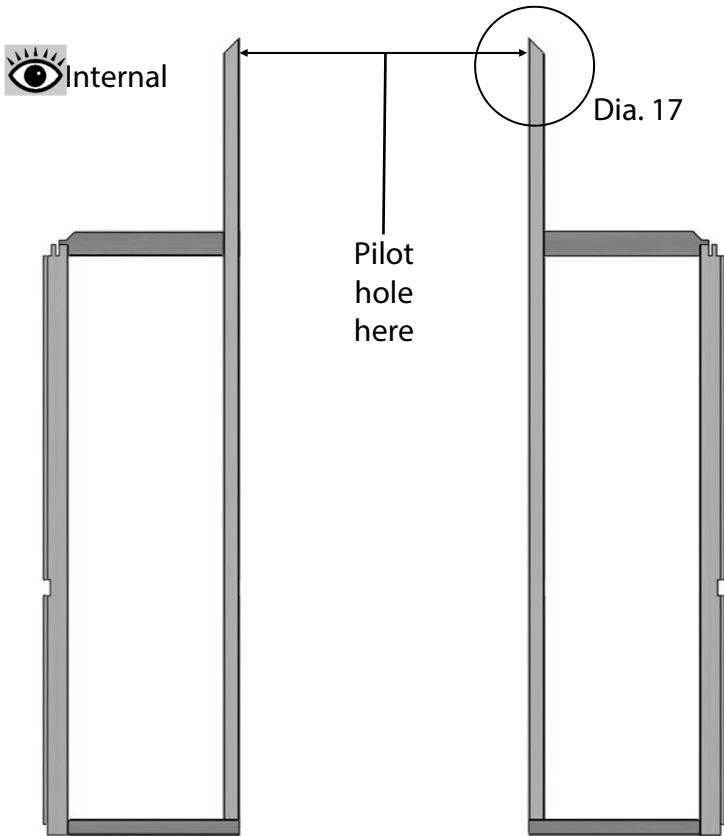

Slot the above purling glazing bars into place ready to take the roof corner bars. You should now drill the pilot holes shown in diagram 17.

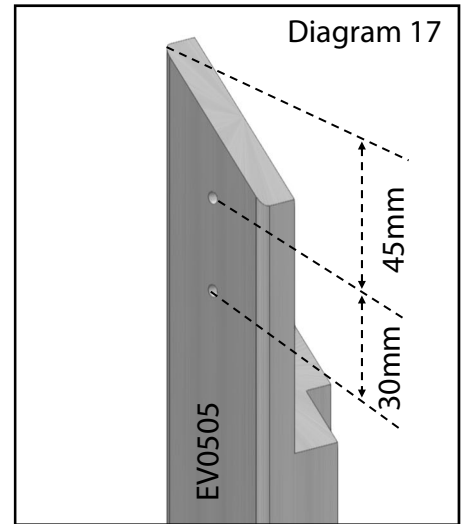

Slot the roof corner bars onto the gable bars and fix with 40mm Pan Head screws (diagram 18).

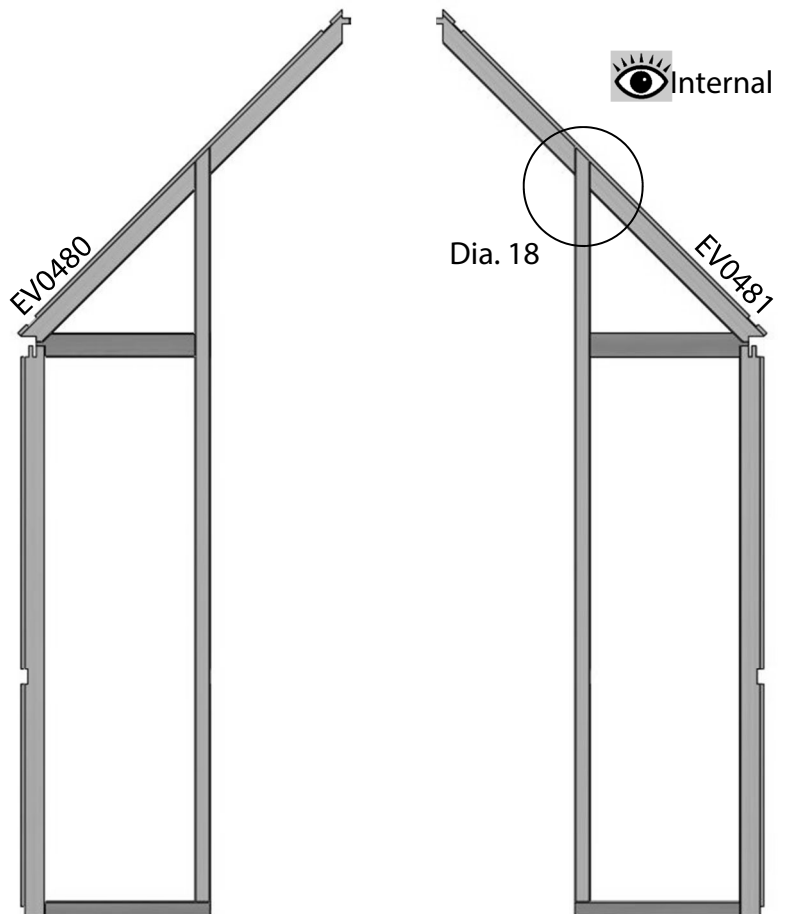
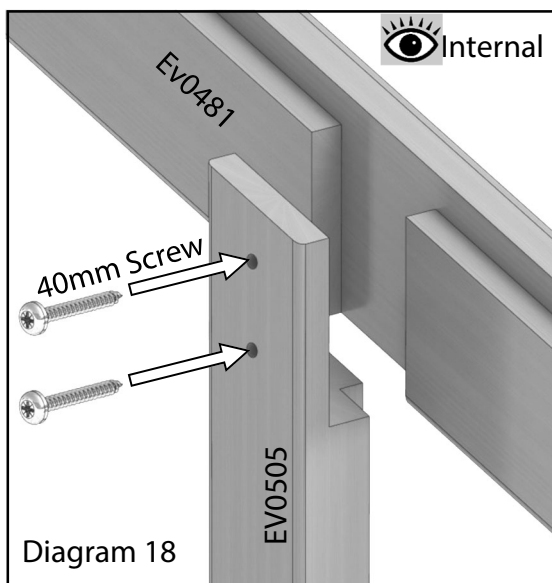

Porch Front Assembly

Flip each gable section over so you can fix the purling bars with 25mm countersunk screws (diagram 19).

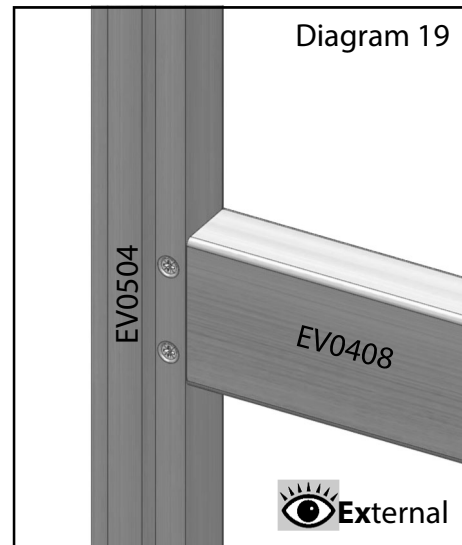
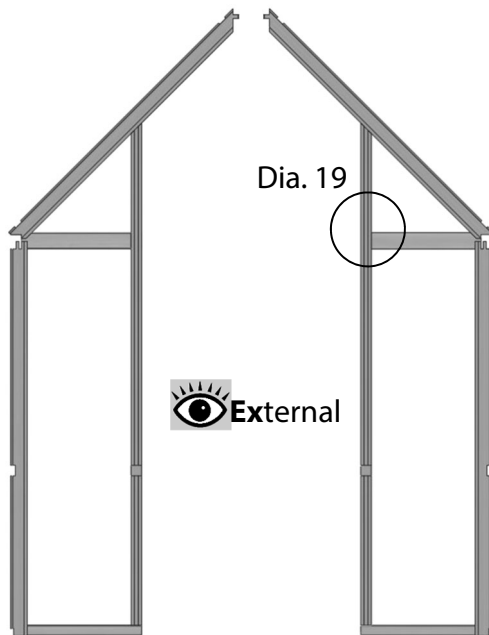

Porch Returns Assembly

Your handed porch returns (diagrams 20 internal view, 23 external view) allow you to connect your end gable assemblies to the front porch assembly. On the 12' returns (shown) the verticals (EV0501) are attached in the same way you attached the same bar in the rear side assembly (diagrams 2 and 3), note that you only need to attach them from beneath to the cills (EV0907) they will be fixed to the eaves (EV0910 / EV0911) later during the assembly of the roof. On the 8' returns (not shown) the EV0501 verticals are not required your cills (EV0906 x 4) and your eaves bars (EV0908 x 2, EV0909 x 2) can not accommodate them.

Porch Returns			
Part Name	Part Number	Qty	
		9x8	9x12
Standard Bar	EV0501	-	2
Porch Internal Batten	EV0791	2	
Porch Internal HB Corner LH	EV0794	1	
Porch Internal HB Corner RH	EV0795	1	
Porch Cill 1'	EV0906	4	2
Porch Cill 3'	EV0907	-	2
Porch Eaves 1' LH	EV0908	2	1
Porch Eaves 1' RH	EV0909	2	1
Porch Eaves 3' LH	EV0910	-	1
Porch Eaves 3' RH	EV0911	-	1
Porch Valley Eaves Casting	EV1158M	2	

The L-shaped reverse corner bars which allow your porch to protrude from the building are made up of two components, a handed corner bar (EV0794 / EV0795) with an additional batten (EV0791) which is attached using 50mm CSK screws, see diagrams 21—24. The reverse corners have tenons that slot onto the eaves bars at the angled point and are then covered with the bracket EV1158M.

Study diagrams 20-25 to see how 50mm CSK and 80mm CSK screws are used to join the pieces together. Remember as before to always pilot drill holes first, see dimensions for optimum hole locations. Take your time to ensure that you have measured correctly as the screw heads will be visible at the end of the build and any errors will result in redundant holes in your timber. The aluminium porch eaves castings (EV1158M) determine where the screws will attach to the eaves rails.

Porch Returns Assembly cont.

Diagram 20

9 x 12
example

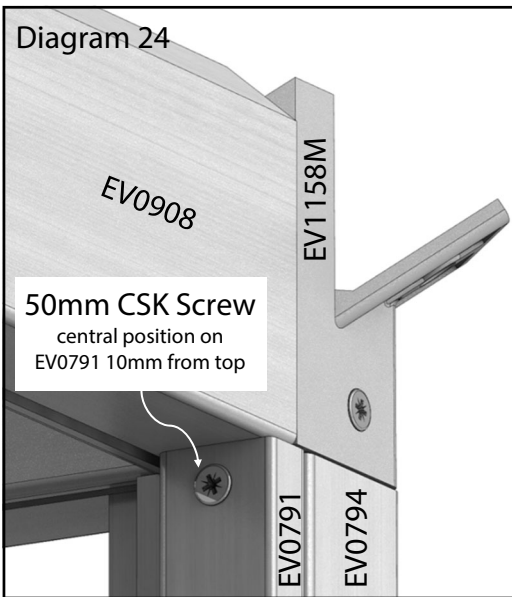
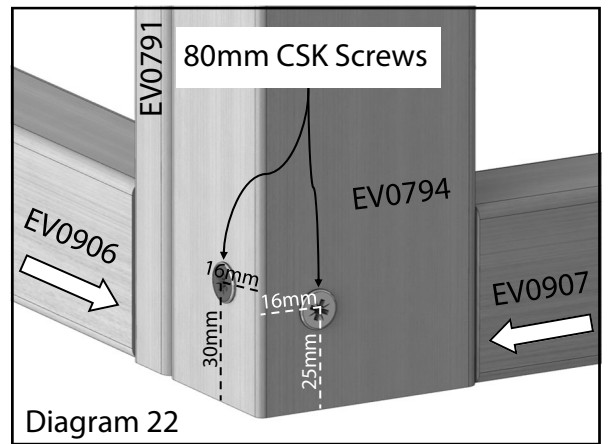
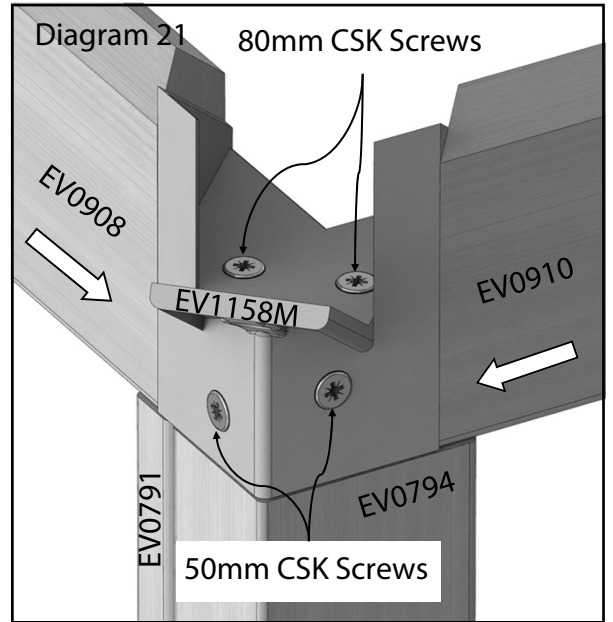
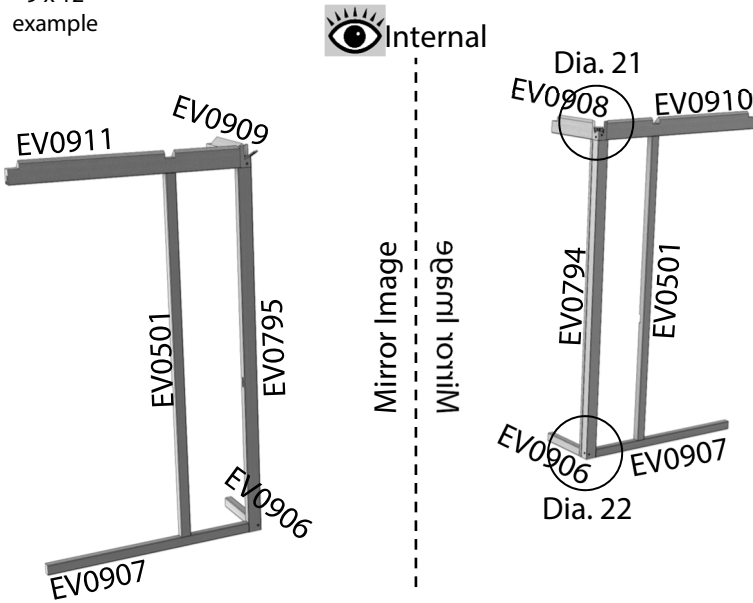

External

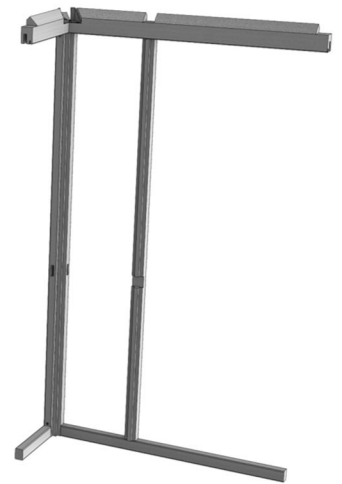
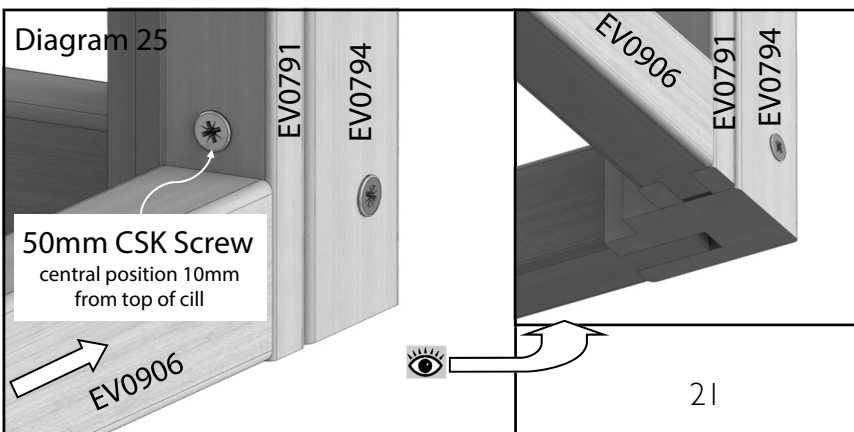

Diagram 23

9 x 12
example



Once complete the two porch returns will be a mirror image of each other and will be ready to be very carefully lifted onto your aluminium base sections shortly.

Frame Assembly

Before you position your sections onto the aluminium base you should drill the pilot holes in the bottom of the end gable side corner bars (EV0502 / EV0503) shown in diagram 28. The position of these holes should be about 19mm from the side face and 30mm measured from the bottom end of the bar.

You can now position the end gable section on the aluminium base, you will need a helper to hold this in place or simply strap it to a set of steps.

Now offer the side assembly (or side 4'/8' extension assembly if your model is longer than 12') slotting the corner bar onto the end of the eaves bar, do not fix this joint as it will be done at a later stage (diagram 27). Screw the bottom of the corner glazing bar to the end of the cill (80mm screw) making sure the rebate for the glass lines up with the front face of the side cill (diagram 28).

Once the side corner bar is in place this will give you the correct position on the aluminium base and you can fix the base to the side cill with 25mm Pan Head screws (EV0331) (diagram 26).

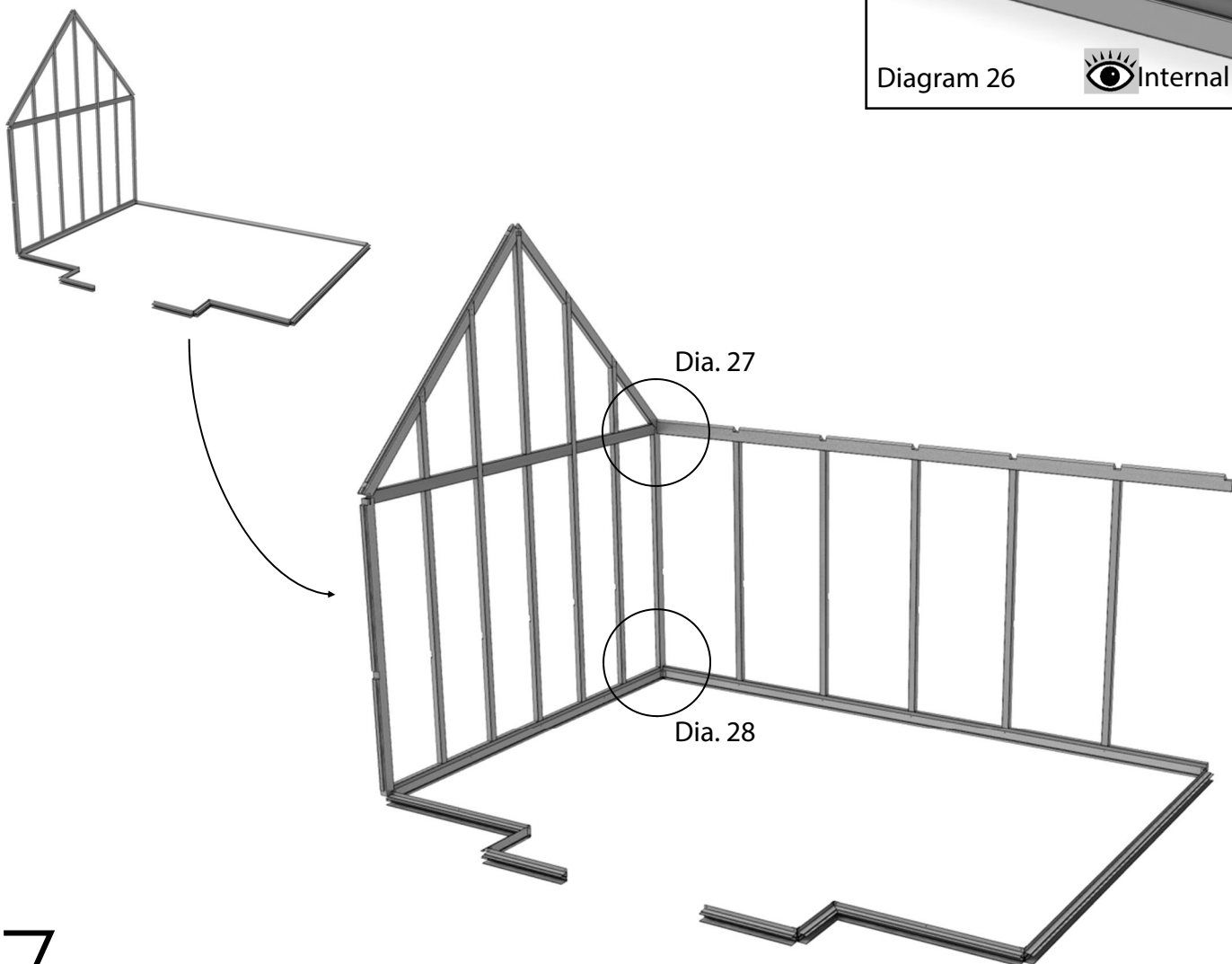
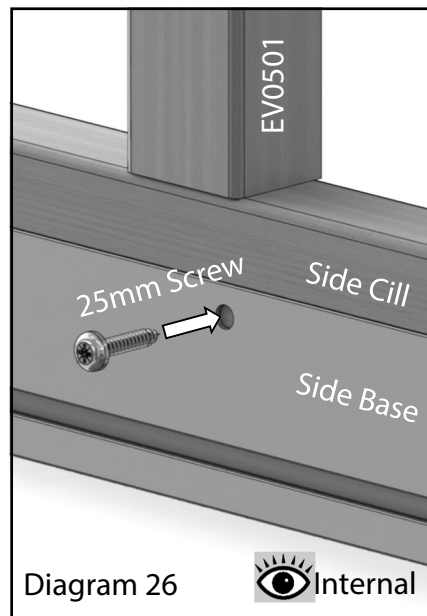

Frame Assembly

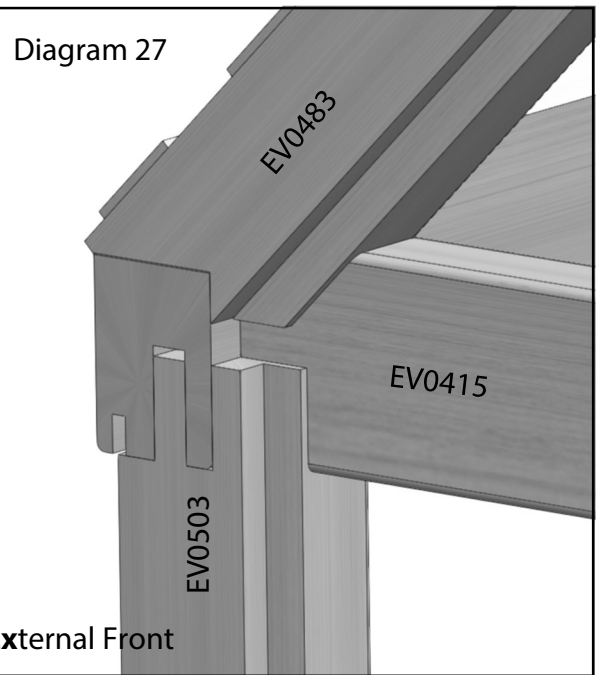
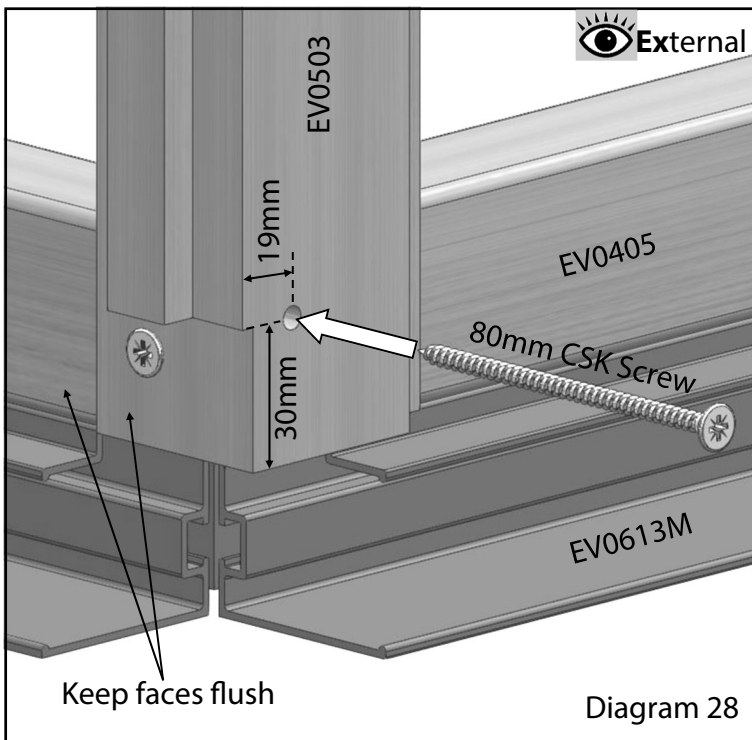

Make sure the side corner bar is located correctly and the front face is flush with the end of the eaves bar, mark out the pilot hole positions shown in diagrams 29 and 30. Diagrams 31 and 32 on the next page show the direction the holes should be drilled in.

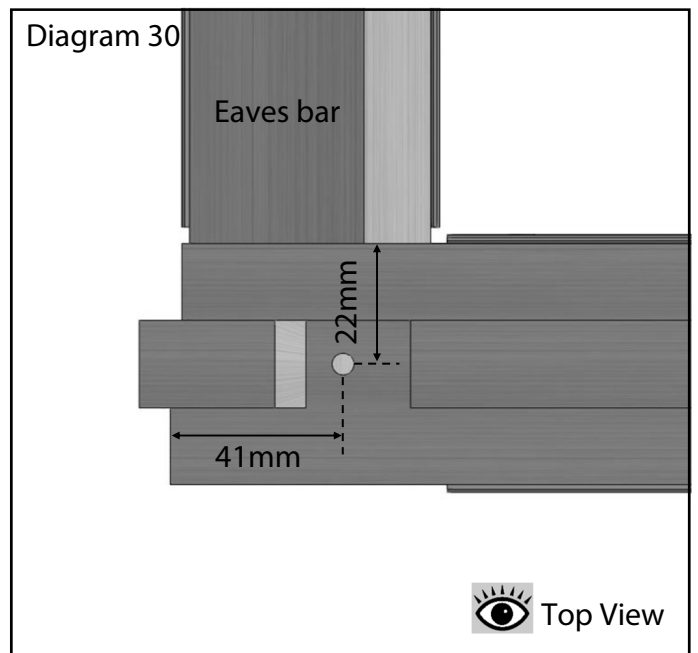
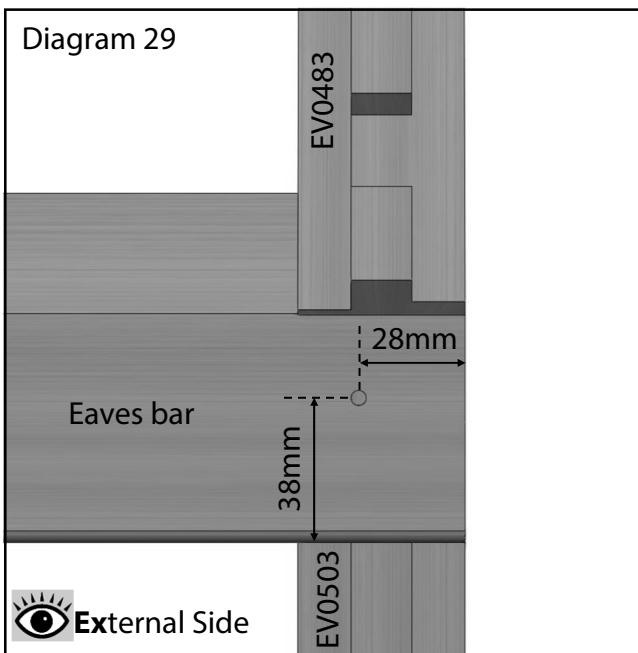

Frame Assembly

Before fixing this corner make sure the inside faces are all flush (diagram 31). When you are happy that the purling is located correctly (it is normal that the purling is set back slightly from the glass rebate on the front of the building) start by inserting the 80mm screw through the side of the eaves bar into the tenon on the end of the purling.

Next insert the 100mm screw vertically down through the roof corner bar into the eaves bar and finally securing the side corner bar (diagrams 32 and 33).

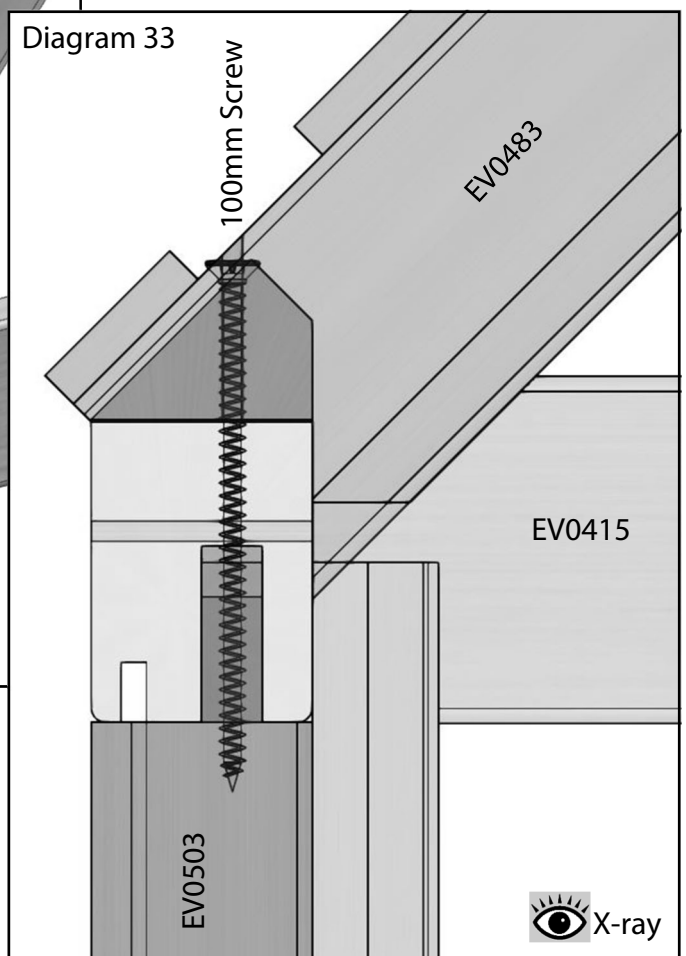
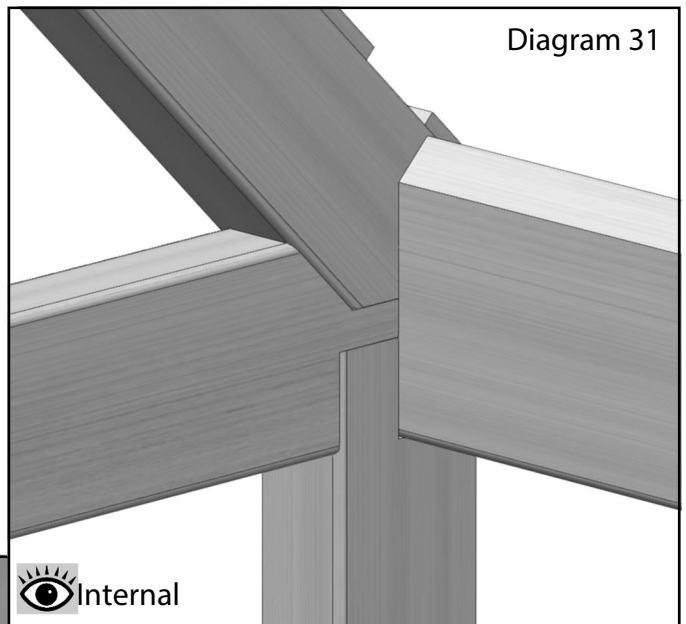

Frame Assembly

With help or using props for extra support, position the other end gable on to the base and repeat the steps from page 22 to 24. It is best NOT to fix this gable to the aluminium base at this point as you will want some adjustment when attaching the porch return side sections, but keep this supported at all times.

Connect the handed porch return sections in a similar manner to the rear side using 80mm and 100mm CSK screws. You may find you need to adjust the corner brackets that hold the aluminium base together to get the corners to meet up correctly. When you are happy with the alignment and have fixed each corner joint you can tighten the nuts on the base corner brackets and fix the timber cills to the base with the 25mm Pan head screws (EV0331).

Finally attach the two halves of the porch front assembly and fix it to the base ready for your door to fit into the doorway.

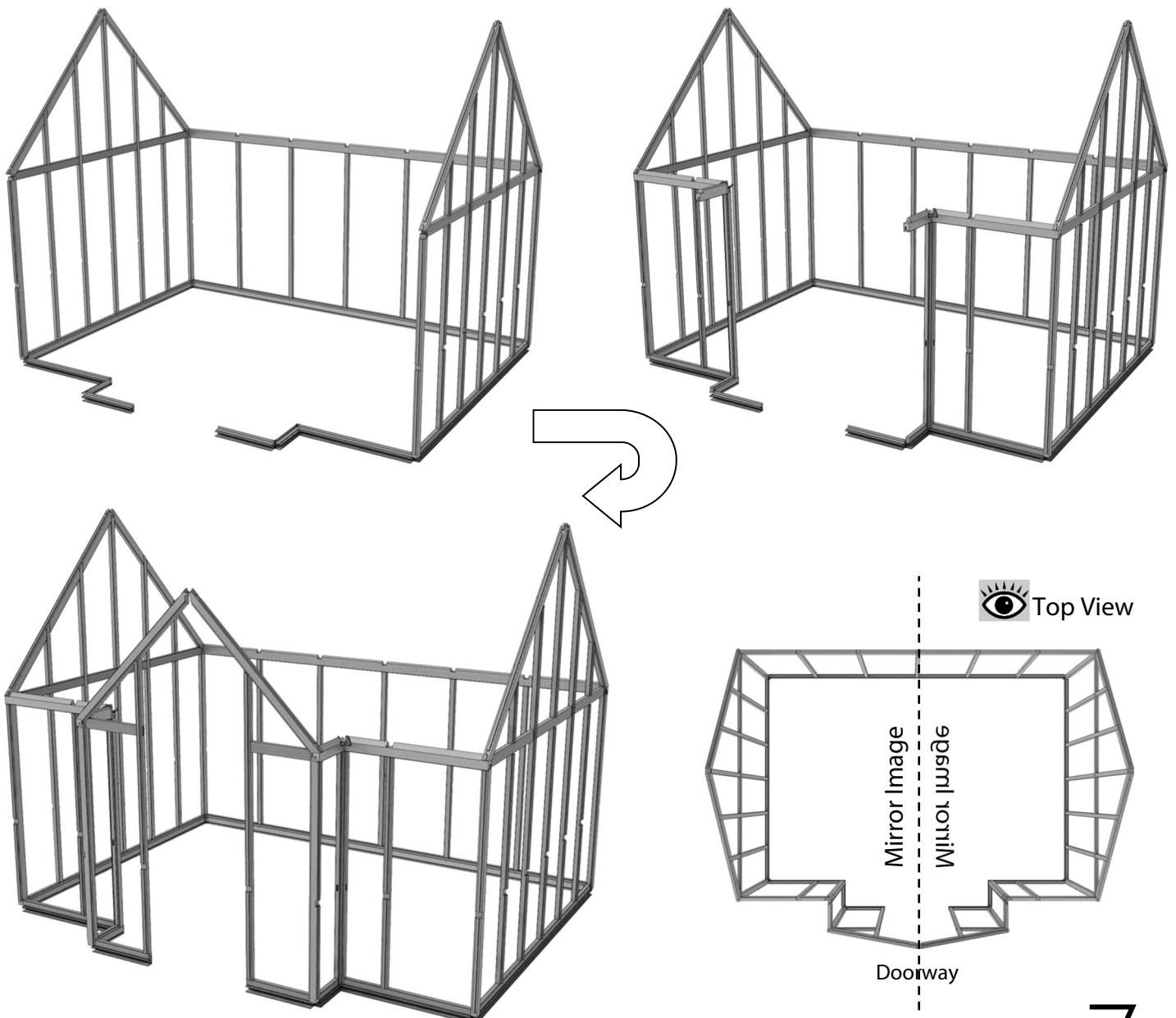

Door Installation

Your door will arrive already installed in the frame with the lock and lock plate attached. All you need to do is attach the door handle to install this to the building.

Start by sliding the spindle through the top hole in the door (diagram 34), then locate one of the door handles on this and fix with the screws provided. Repeat this on the other side of the door (diagram 35).

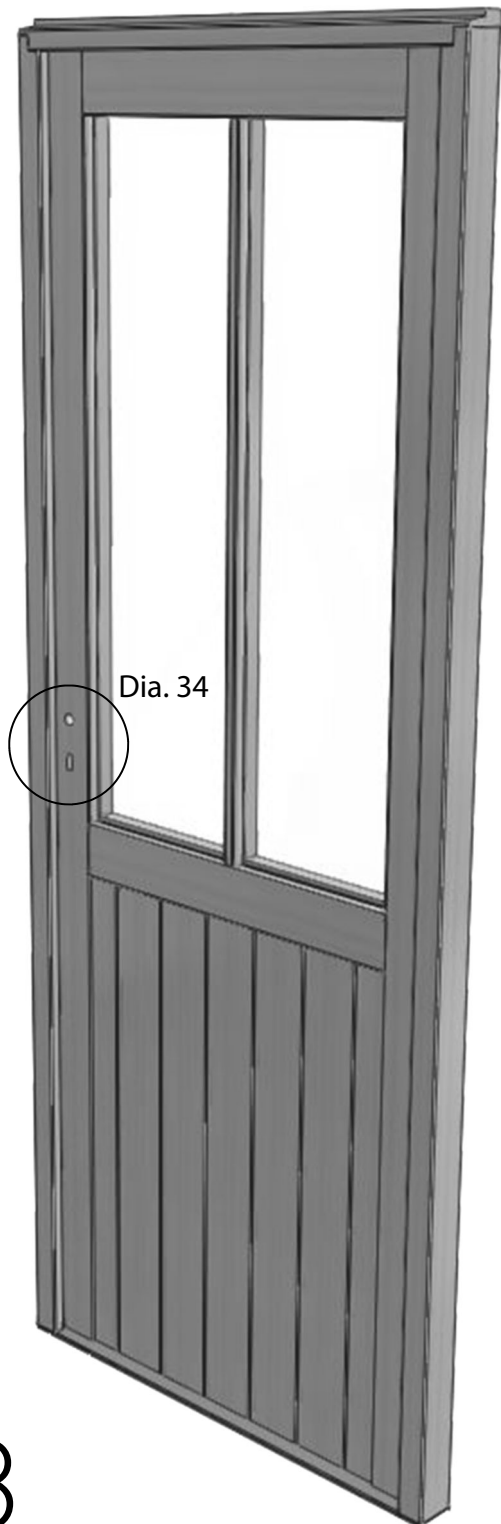

 External Views

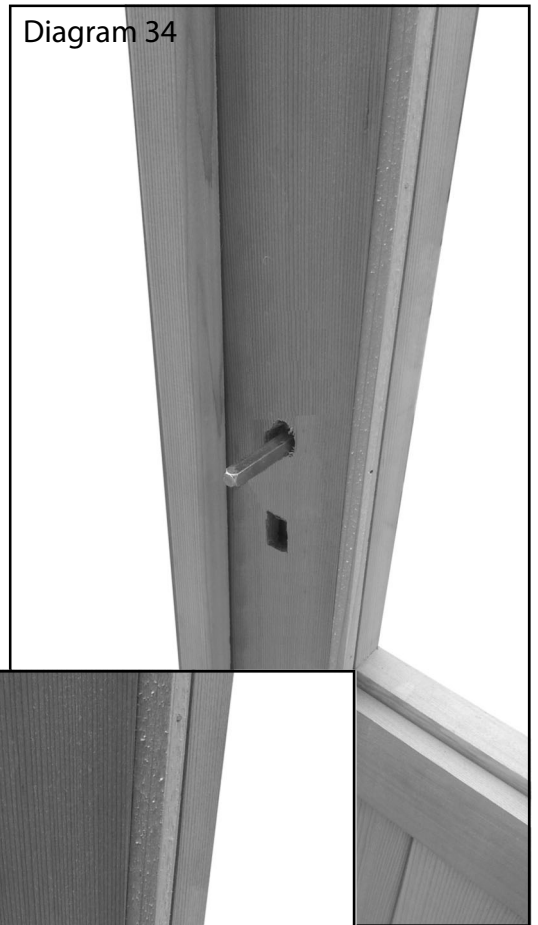

Door Installation

Take the door to the greenhouse frame assembly and slide it into place. Unlock and open the door so that it is 90 degrees to the frame as shown in the illustration on the next page.

You will need to pack the outside edge of the open door, ideally with a wedge so you have some adjustment or simply with some scrap cardboard from the packaging. This will help you get the frame in the correct position for fixing.

To start with you only need to put 4 fixings in the frame, one on either side at the top and the same at the bottom. The 50mm CSK screws should go through the same face that the strike plate is mounted on and where the hinges are mounted on the other side. The back of the frame should line up with the inside face of the gable glazing bar, this should then also mean that the glass rebate on the frame header will line up with the rebate on the gable glazing bars (diagram 37).

When you are happy with the position of the frame fix it with the 50mm screws as shown on the next page. This is only an initial fix and adjustments can be made later.

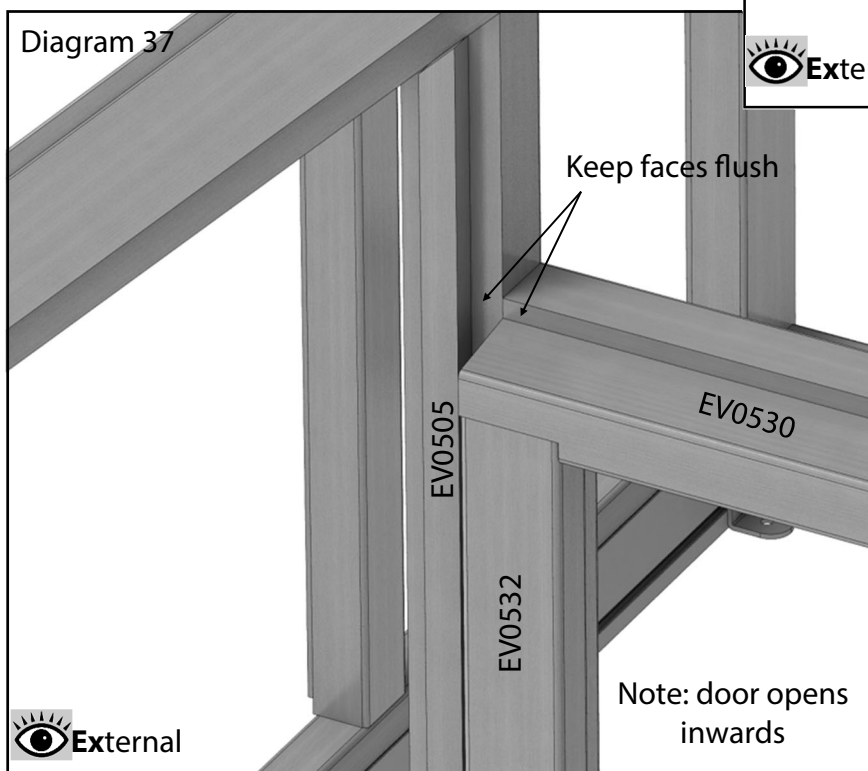
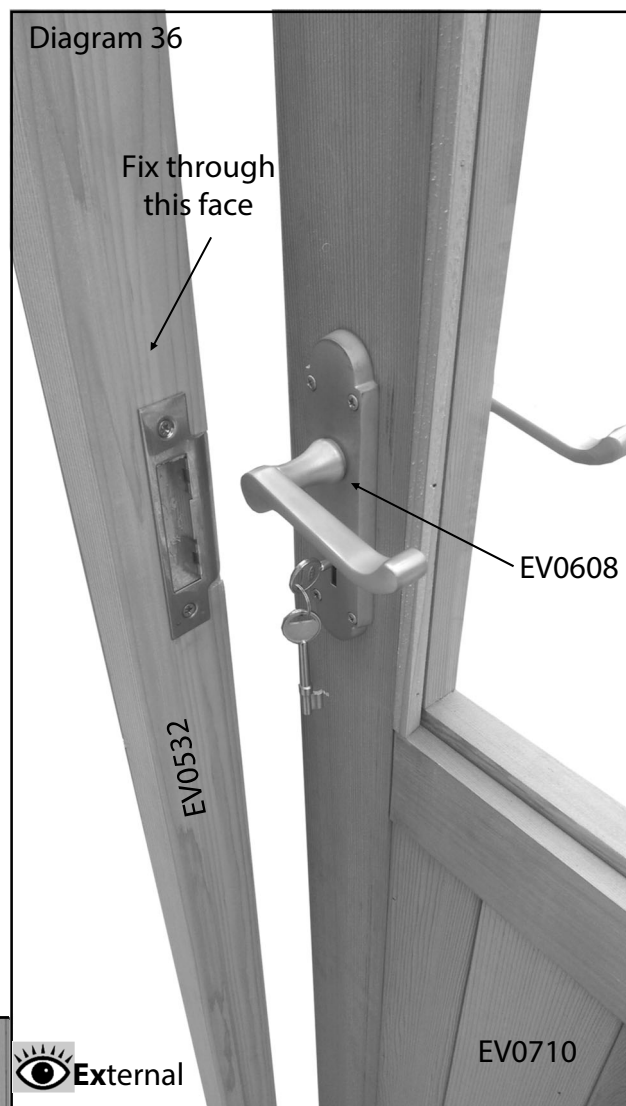

Door Parts		
Part Name	Part Number	Qty
Door Lock	EV0606	1
4" Hinges	EV0607	3
Door Handle Set	EV0608	1
Single Door	EV0710	1

Door Installation

Once the door frame is secure drill a pilot hole through the mortise slot in the door frame header (diagram 38).

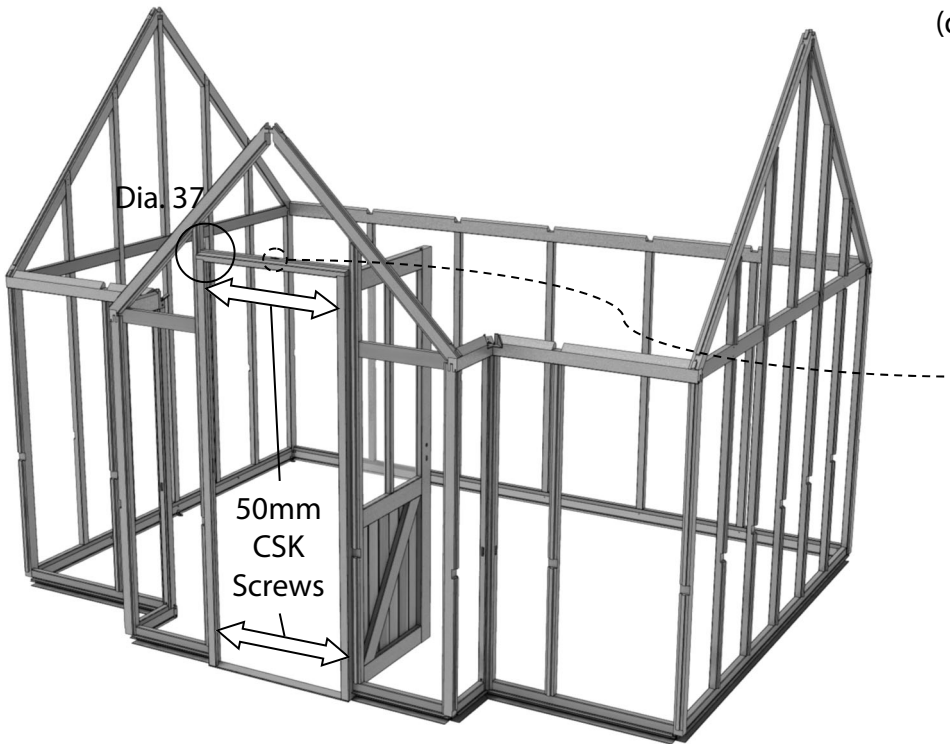

Slot the above door glazing bar (EV0471) into the mortise slot in the door frame header and secure it with a 50mm CSK screw (diagram 39).

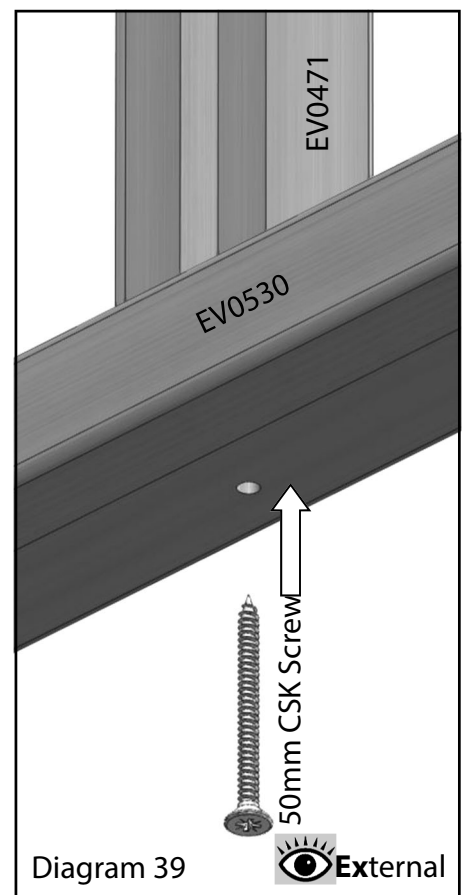
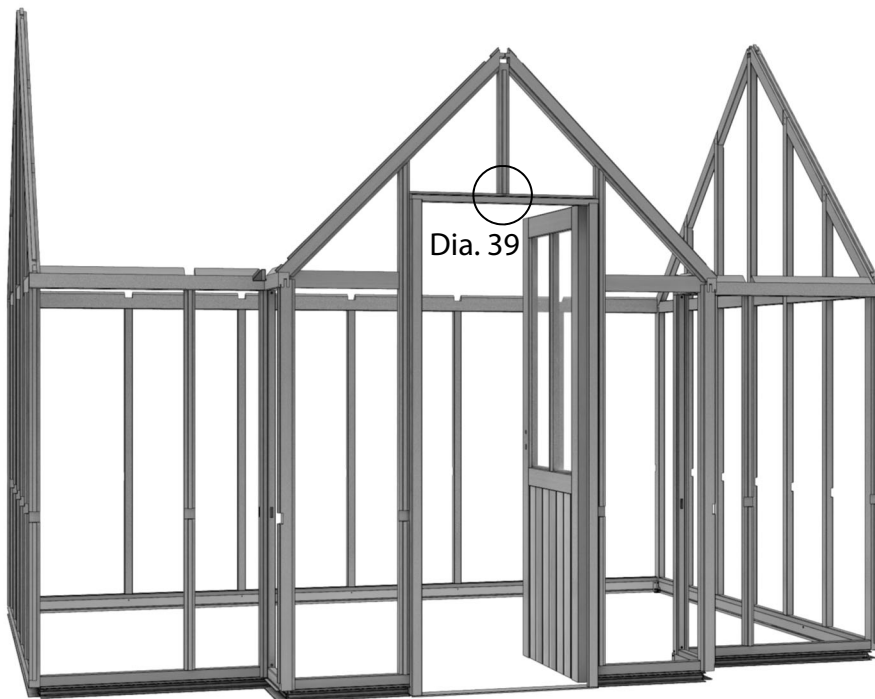

Roof Assembly

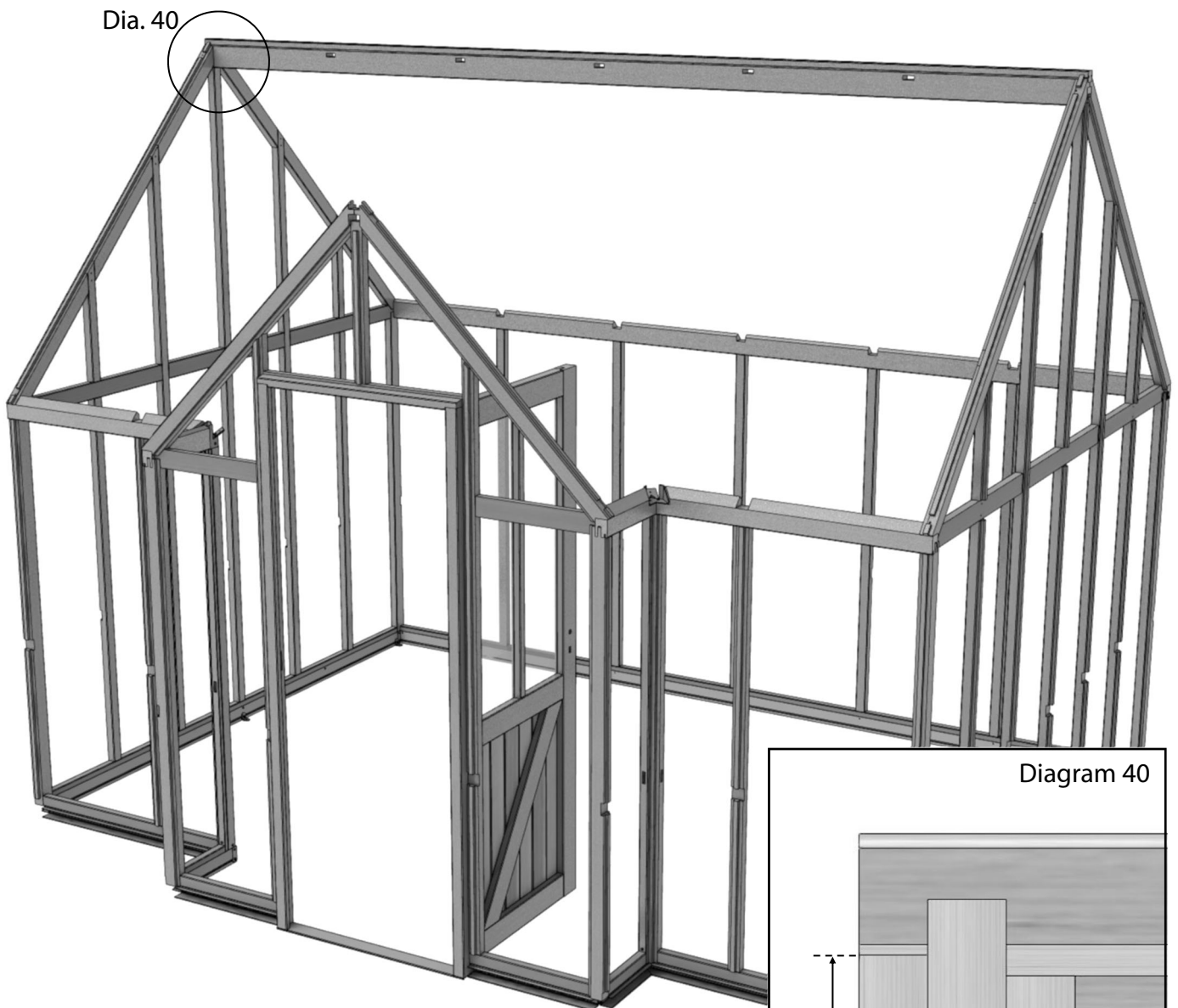

You will need two sets of step ladders at this point and a helper. Slot the ridge bar (8' - EV0445 / 12' - EV0447) onto the tenons of the roof corner bars at both gable ends of the building. The central glazing bars should locate with the ridge bar below this joint (diagrams 40 to 43).

Once in place still with your helper securing one end drill the roof corner glazing bars as shown in diagram 40. The pilot holes should be drilled horizontally and off centre as shown so that the screw on the other side misses this screw. If you always drill the holes for the roof bars 18mm from the left hand side of the bar this will prevent any problems. Fix the roof corner bars with 80mm CSK screws (diagrams 41 to 43).

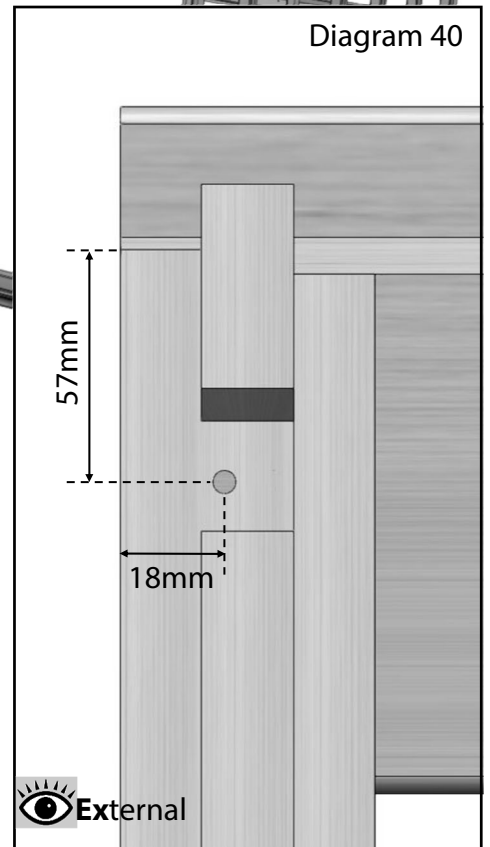

Roof Assembly

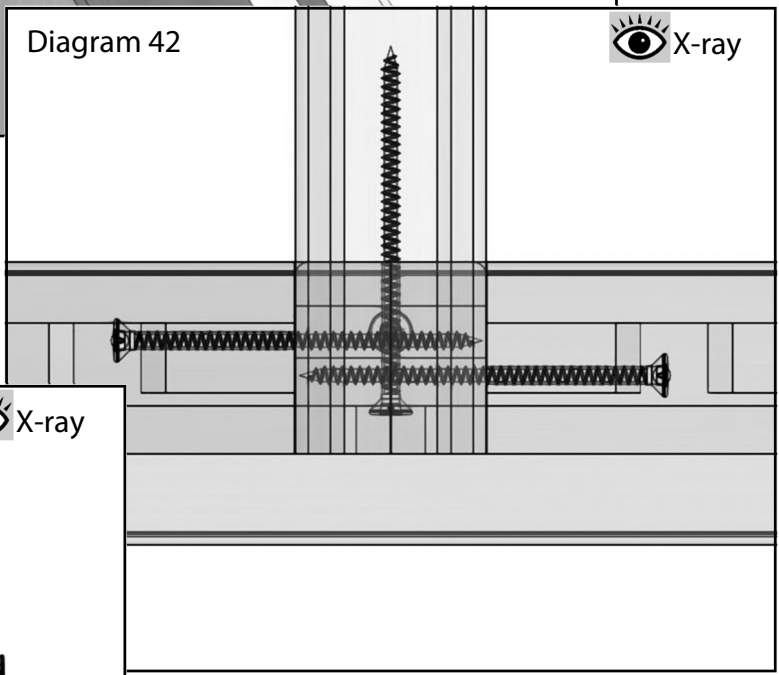
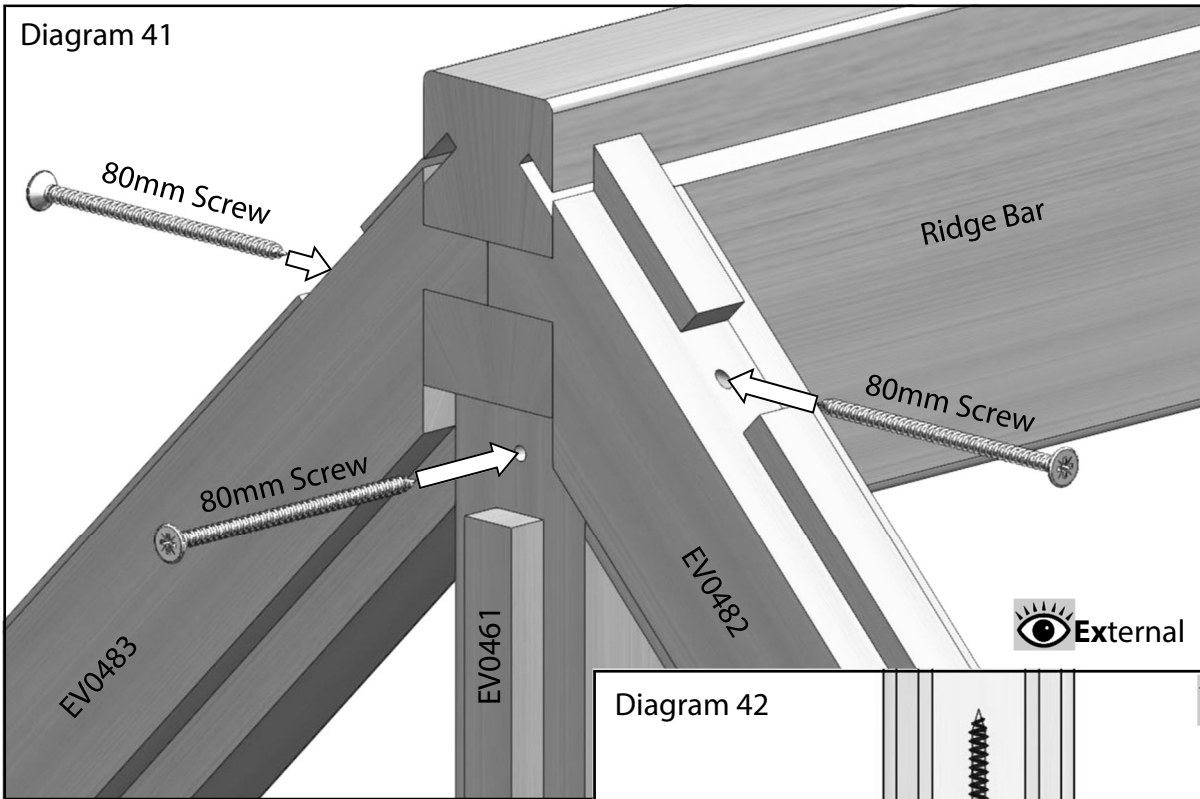

The central glazing bars should also have a pilot hole drilled and be fixed to the ridge bar with an 80mm CSK screw (diagrams 41-43).

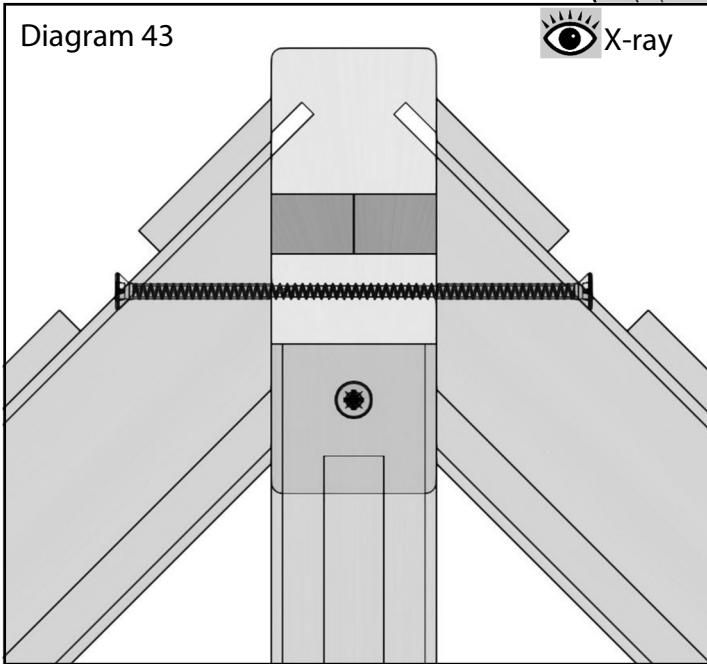

Roof Assembly

Now the ridge is in place you can install the roof bars. Slot the bars into the ridge first, the tenon may be a little tight so this might require a tap with a wood or rubber mallet. Once this has located correctly locate the bottom of the bar with the trench in the eaves bar/s. This again may require some persuasion to get this to drop into place. Once the bar is fitted at both ends drill a pilot hole at the top of the bar as shown in diagram 44. This again should be drilled off centre as the roof corner bars were in diagram 40. Now fix with an 80mm screw. Don't fix the bottom until all the roof bars are in place.

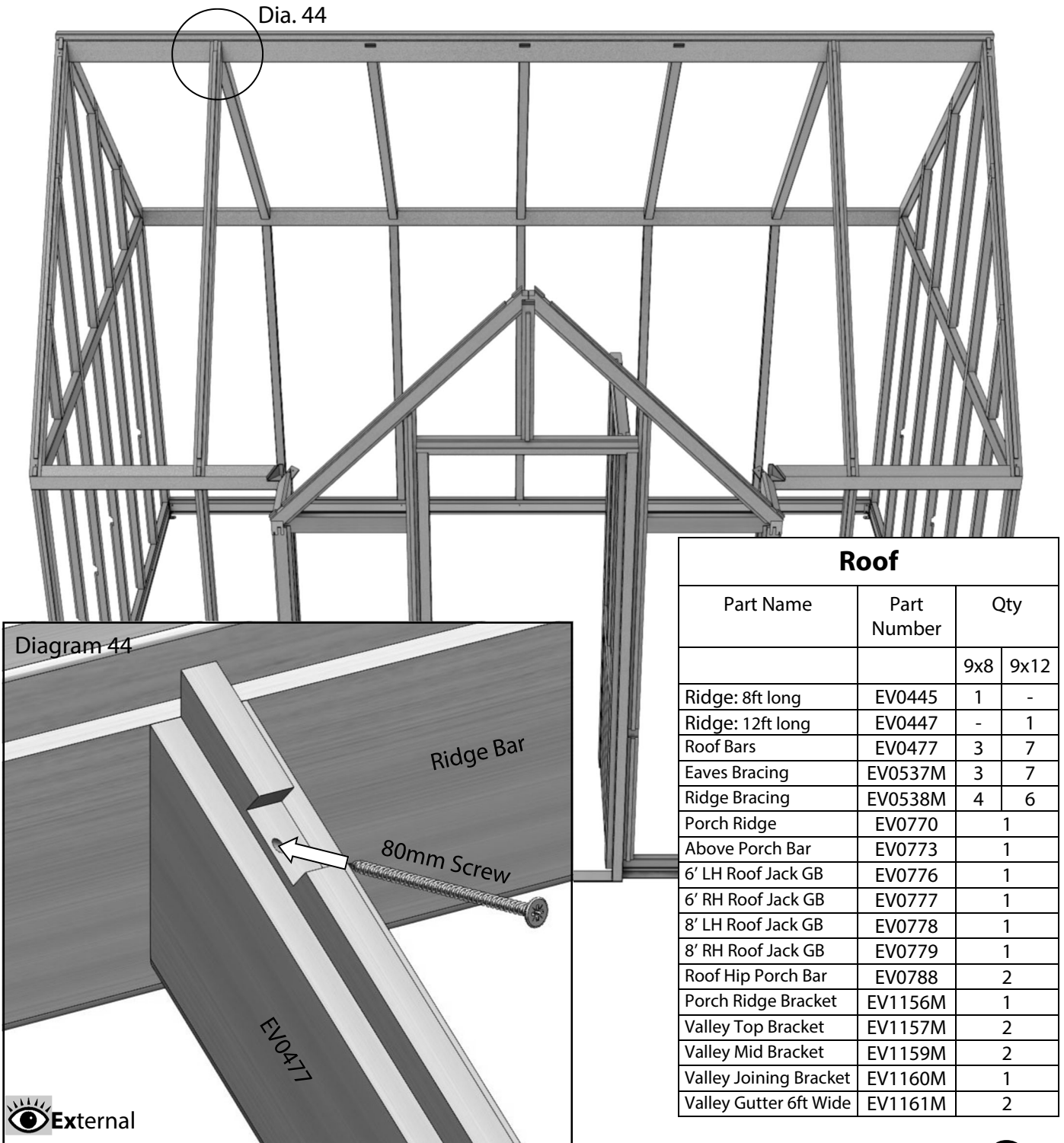

Roof			
Part Name	Part Number	Qty	
		9x8	9x12
Ridge: 8ft long	EV0445	1	-
Ridge: 12ft long	EV0447	-	1
Roof Bars	EV0477	3	7
Eaves Bracing	EV0537M	3	7
Ridge Bracing	EV0538M	4	6
Porch Ridge	EV0770	1	
Above Porch Bar	EV0773	1	
6' LH Roof Jack GB	EV0776	1	
6' RH Roof Jack GB	EV0777	1	
8' LH Roof Jack GB	EV0778	1	
8' RH Roof Jack GB	EV0779	1	
Roof Hip Porch Bar	EV0788	2	
Porch Ridge Bracket	EV1156M	1	
Valley Top Bracket	EV1157M	2	
Valley Mid Bracket	EV1159M	2	
Valley Joining Bracket	EV1160M	1	
Valley Gutter 6ft Wide	EV1161M	2	

Roof Assembly

With all the roof bars in place drill pilot holes vertically down through the roof bars, refer to diagram 30 (page 23) for the location of this hole. Make sure the roof bars are tight in to the eaves bar on the inside of the building and fix with 100mm screws (diagrams 45 and 46).

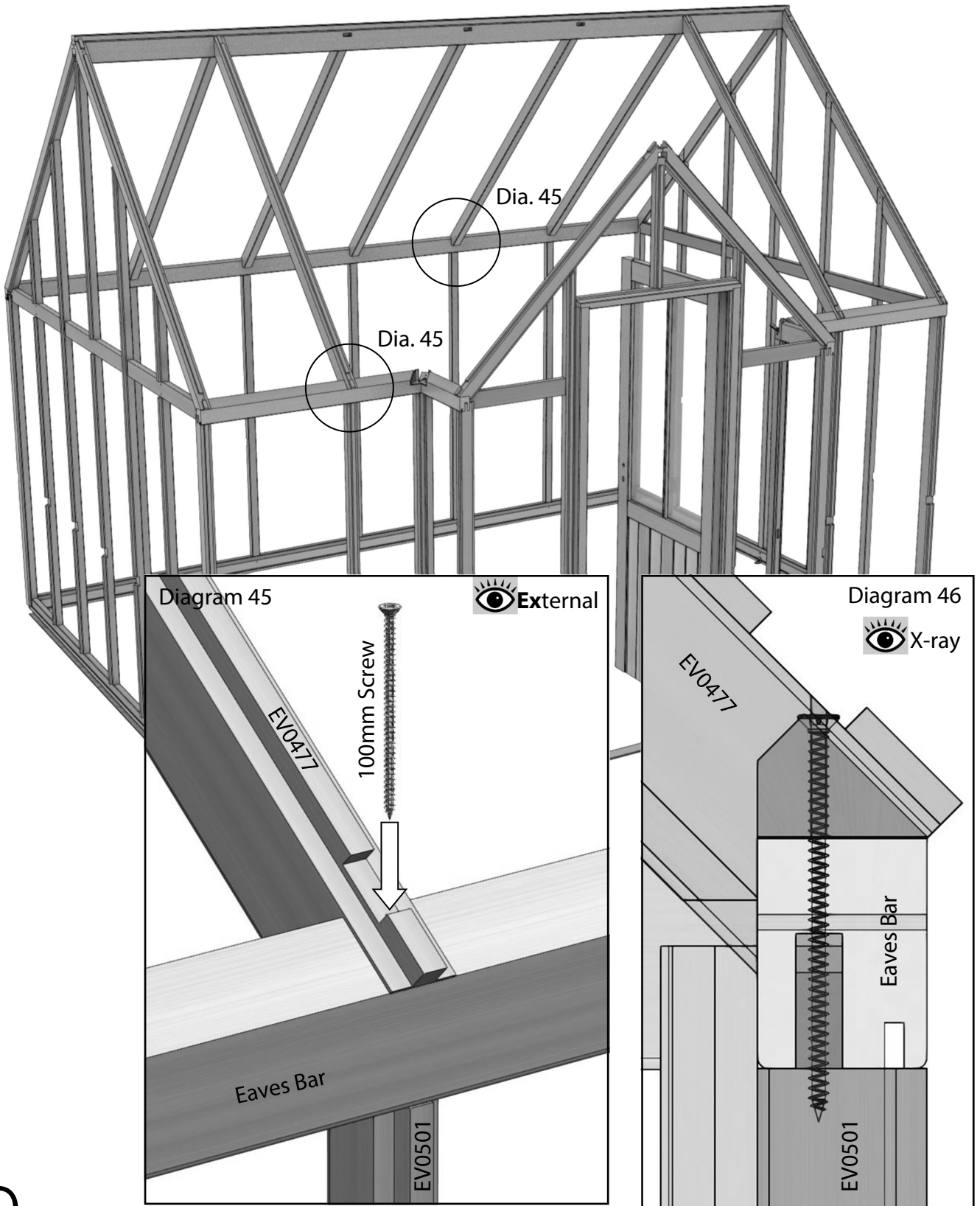

Roof Assembly

Before you begin construction of the porch roof you firstly need to check that your building is square and level, are the internal diagonal measurements equal? With so many precision components meeting from different directions you need to take time now to aid construction throughout the rest of the build.

Your porch ridge (EV0770) is attached to your above porch short glazing bar (EV0773) using a metal porch ridge bracket (EV1156M) and four 50mm pan pozi screws (EV0367) (diagram 47). Silicone should be added between the ridge and the short glazing bar to ensure that water is not drawn through the joint, once the greenhouse is complete this area is difficult to access so spend time now ensuring that everything fits tightly and is sealed. You can support the weight on the joint between EV0770 and EV0773 with a roof spandrel (EV0538M), page 35.

Your porch ridge attaches to the porch gable in the same way that your standard ridge met the end gables (diagram 41) and the short roof bar is attached again in the standard fashion (diagram 44).

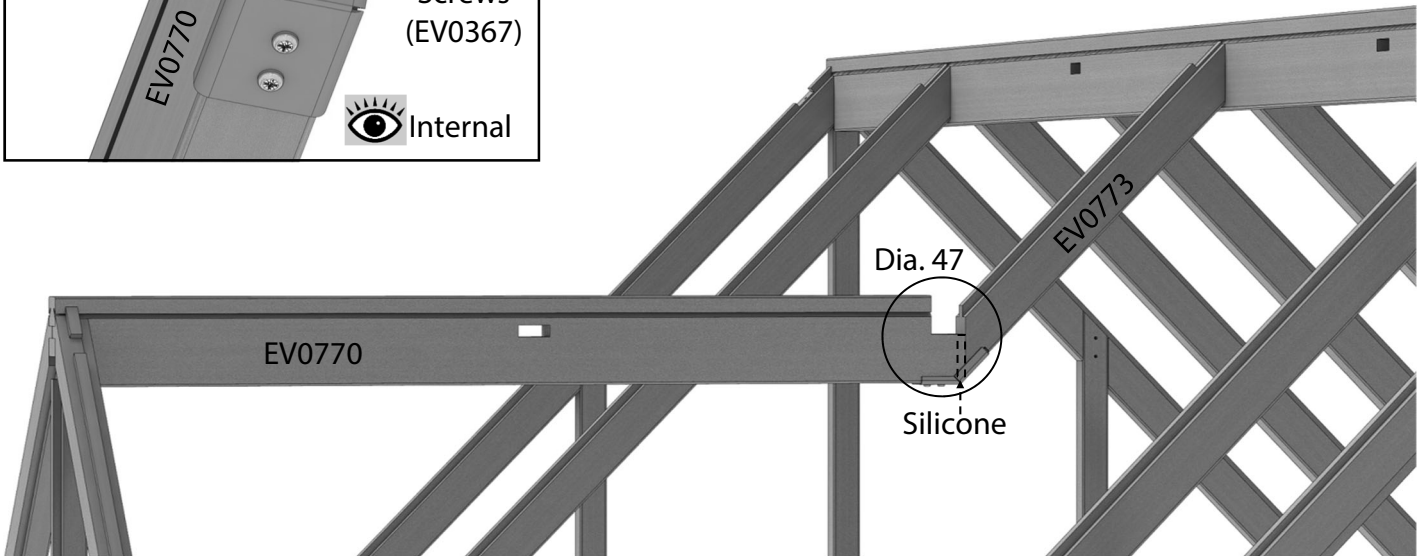
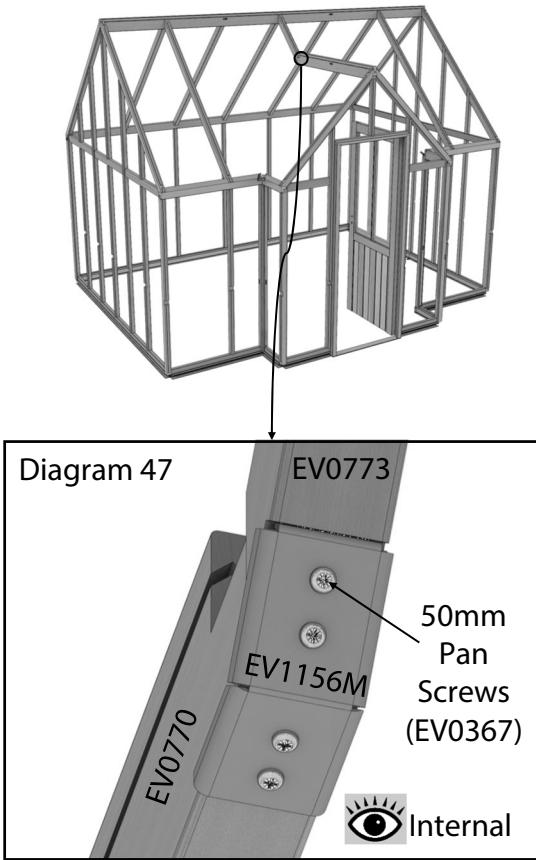

Two EV1157M brackets are now attached flush to the end of EV0773 as per diagram 48 with 25mm CSK screws (4 in total). These brackets will support to the top end of your roof hip porch bars, you have already installed the brackets which support the bottom end when you built your porch return assemblies (diagram 21).

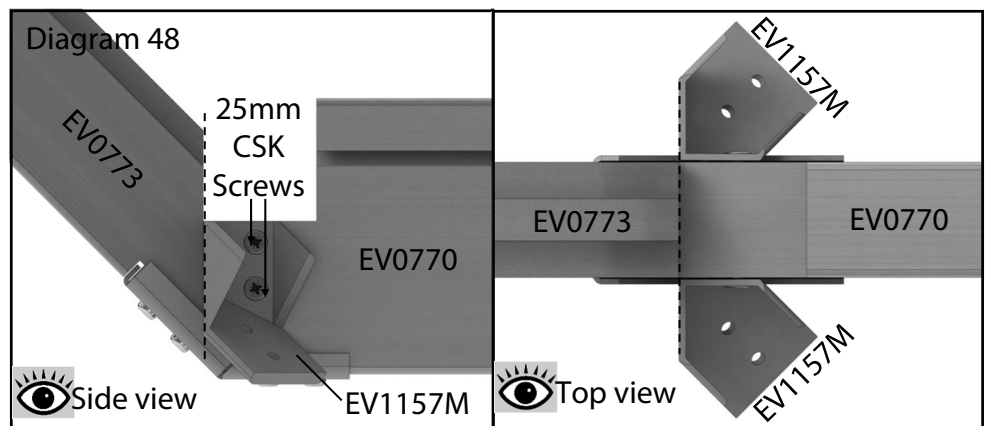

Roof Assembly

 Bottom view

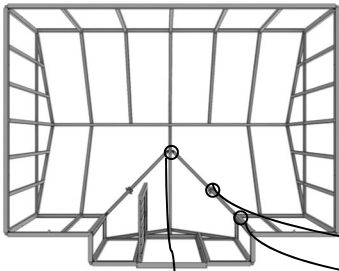

Your roof hip porch bars (EV0788) can now each be lowered into place (pointed end towards the porch ridge) and secured with two 25mm csk screws at the top (diagram 49) and one at the bottom (diagram 50). The four remaining empty holes in the EV1157M's are redundant on this model.

On each hip (EV0788) you will notice a notched out section on the underside face. These house your hip mid brackets (EV1159), the wider part of the castings are orientated towards the eaves bars / ground and are again attached with a 25mm csk screw (diagram 51).

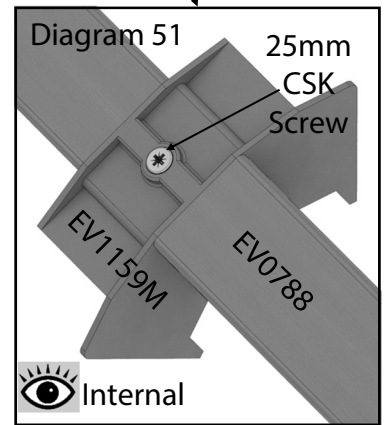
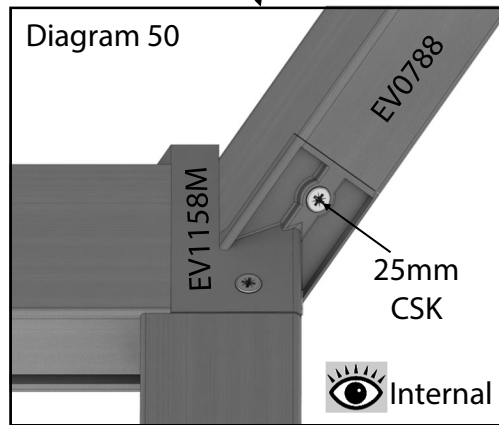
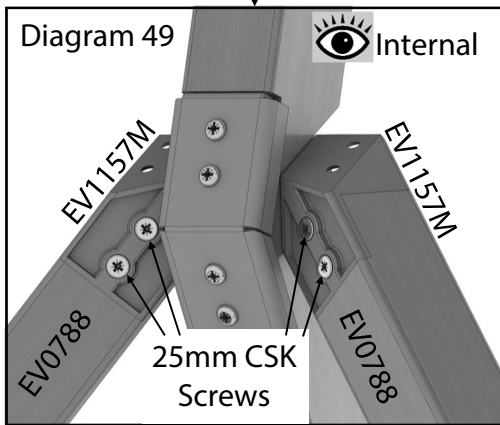

The porch valley gutter top bracket (EV1160M) can now be loosely inserted into the recess between the end of your porch ridge and the above porch small glazing bar. The aluminium roof hip gutter channels (EV1161M) now need to be fed up onto that bracket from each side, see diagram 52. Once both gutter channels are in place the bracket can be secured with a 50mm pan head screw from above. Add silicone where shown to create a seal between the three parts, diagram 52.

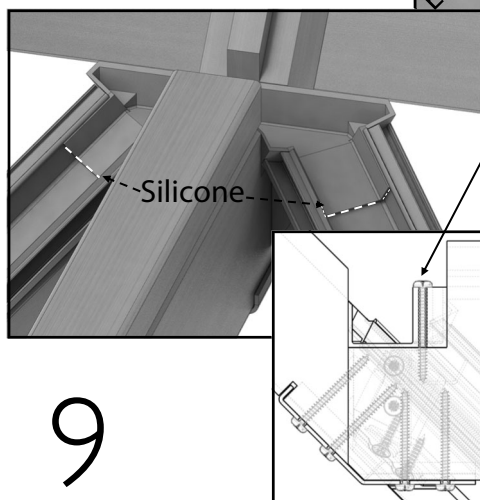
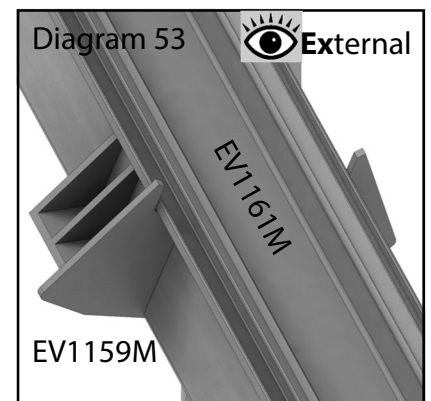
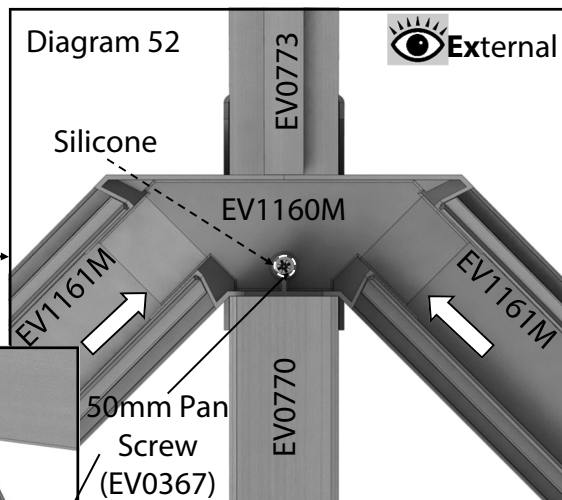
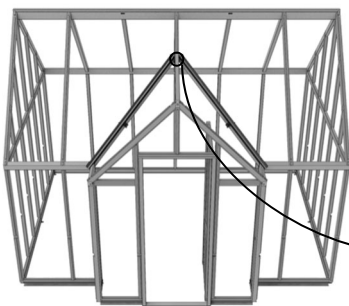

Carefully press down along the length of the aluminium roof hip gutter channels (EV1161M) so that they are fully bedded into the wood below them (diagrams 53 and 54).

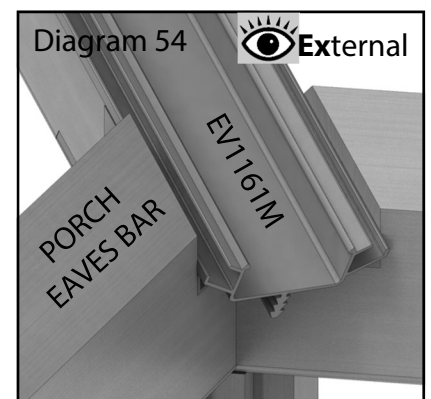

Roof Assembly

The handed roof jack glazing bars now need to be fitted, see diagrams 55 and 56. They attach to the ridge and porch ridge as per previous roof bars using 80mm CSK screws. The bottom of each bar (EV0776, EV0777, EV0778, EV0779) rests onto the EV1159M brackets. Mark the hole locations shown in diagram 55 and then pilot drill the holes observing the recommend angle for the drill bit. 80mm CSK screws are then used to join each jack to the roof hips (EV0788).

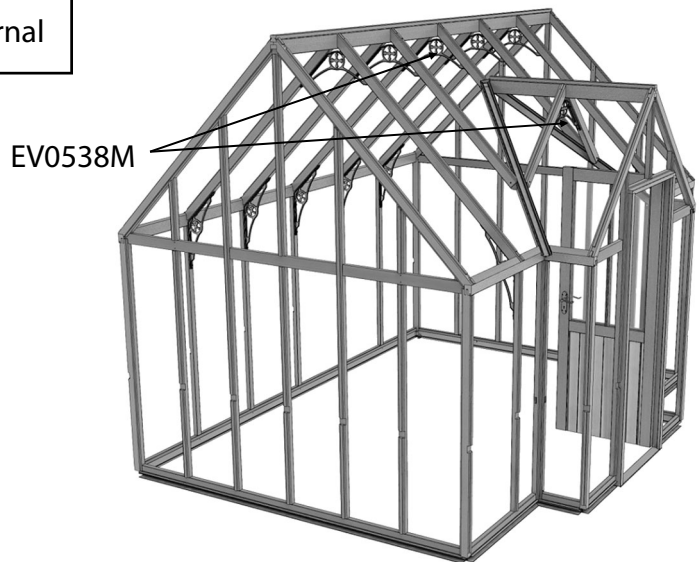
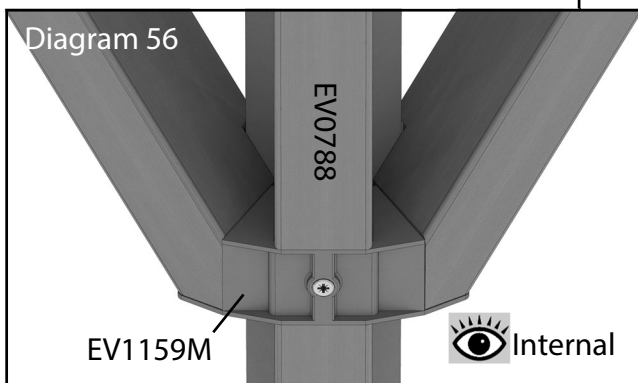
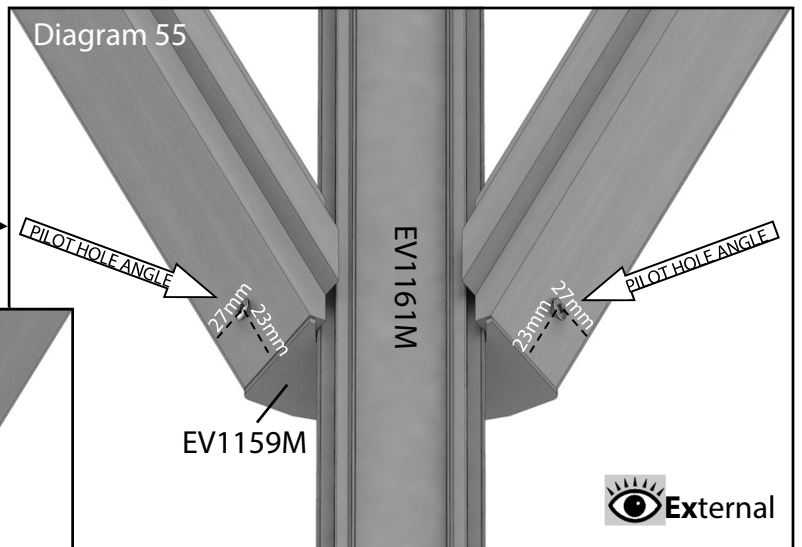
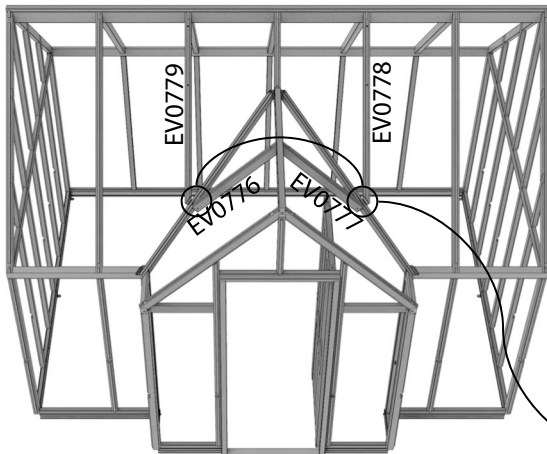

Now all the roof bars are in place and fully secured you can fit the eaves bracings (EV0537M) and ridge bracings (EV0538M). These are fitted centrally to every available roof and side bar in the building. Use 40mm Pan head crews to fix these to the building (It looks better if you have all the manufacturing marks facing away from the door aperture).

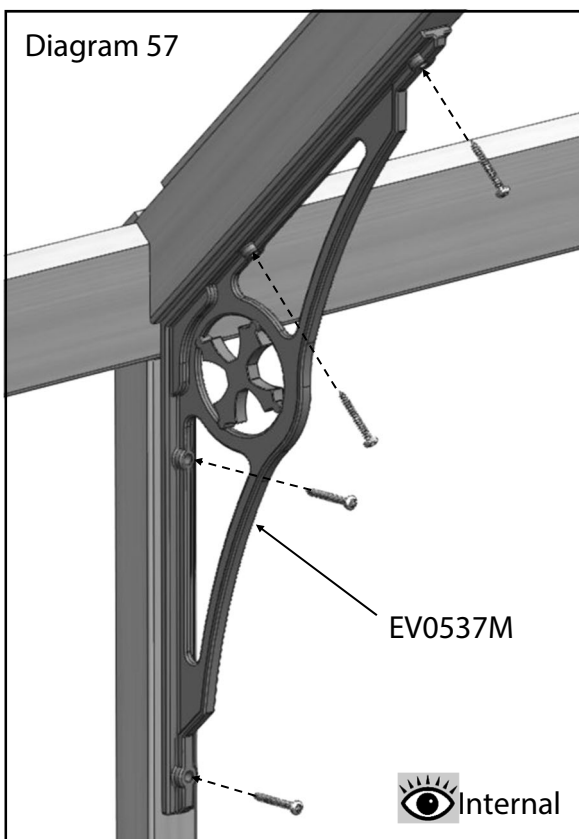

Mid Rail Installation

Once the greenhouse frame is up and secured to the aluminium base using 25mm Pan Heads you can install the mid rails, starting with the rear side.

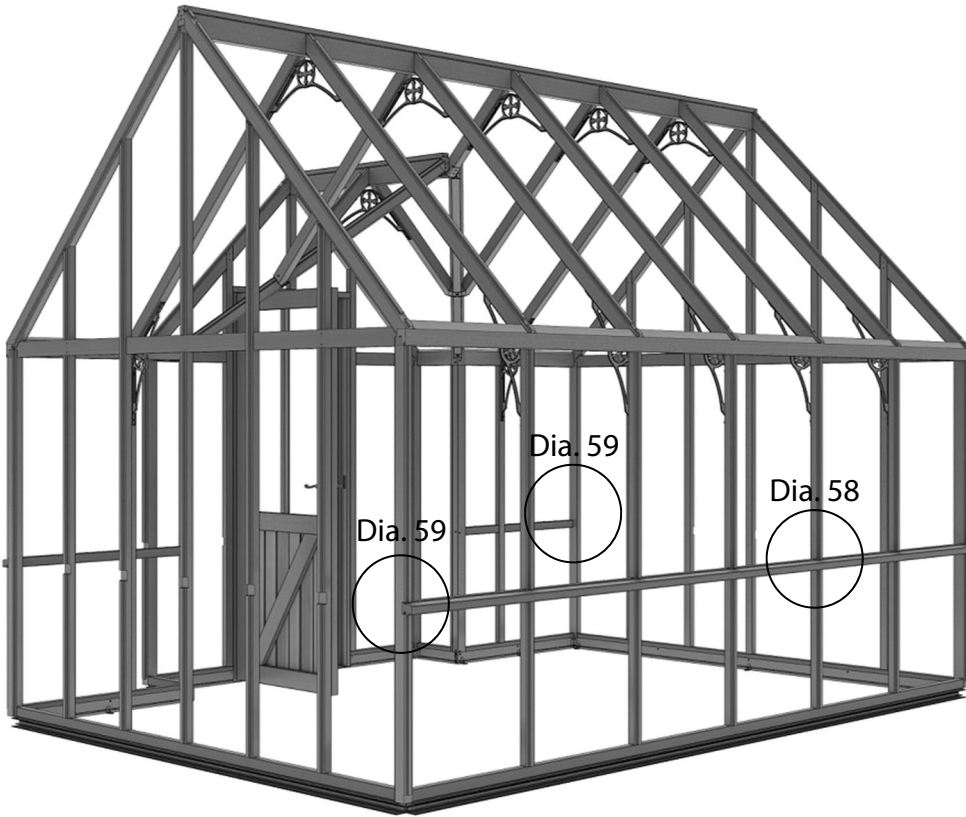

8ft long			
Part Name	Part Number	Size (mm)	Qty
Front R	EV0424	576	1
Front L	EV0425	576	1
End Gable	EV0433	2707	2
8' Side	EV0438	2564	1
1' LH Mid	EV902	329	2
1' RH Mid	EV903	329	2

12ft long (shown)			
Part Name	Part Number	Size (mm)	Qty
Front R	EV0424	576	1
Front L	EV0425	576	1
End Gable	EV0433	2707	2
12' Side	EV0440	3824	1
1' LH Mid	EV0902	329	1
1' RH Mid	EV0903	329	1
3' LH Mid	EV0904	960	1
3' RH Mid	EV0905	960	1

Slot the mid rail onto the rear of the greenhouse. Drill pilot holes in the rear side bars from the inside of the building and fix with 50mm CSK screws, diagram 58. Then drill pilot holes in the corner bars and fix with 80mm CSK screws, diagram 59. The front rails adjacent to the porch can now be attached in a similar manner (8' = EV0902 / EV0903, 12' EV0904 / EV0905).

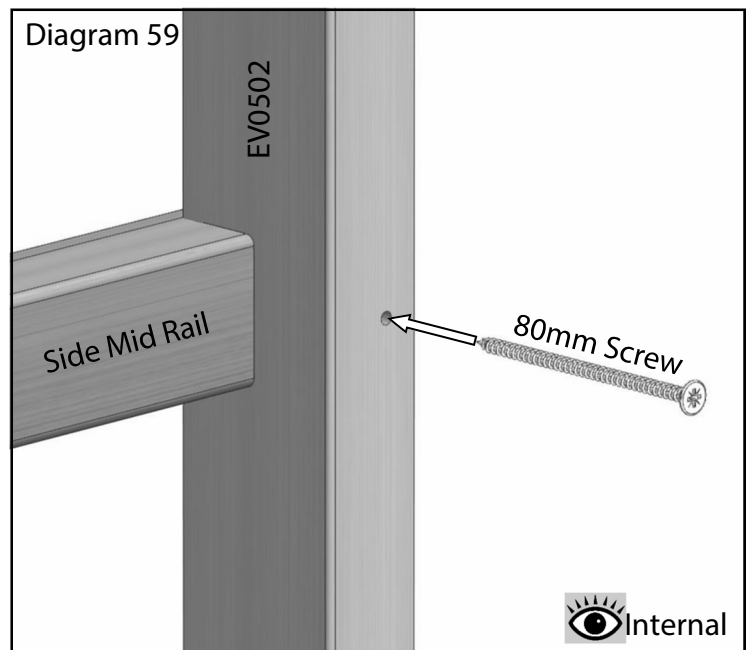
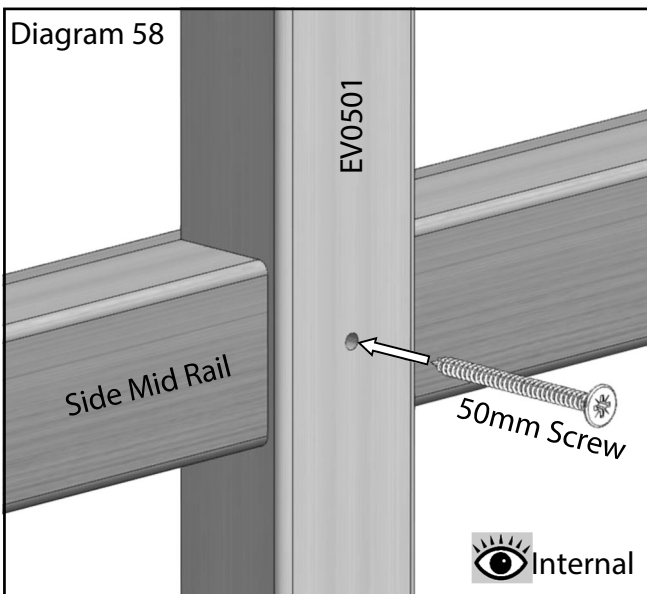

Mid Rail Installation

Now Fit the mid rails to the end gables. Again slot them into place, pilot drill internally and fix them with 50mm CSK screws through the gable bars and corner bar.

Make sure the two mid rails are lined up well on the outside before fixing to the corner bar (diagram 60).

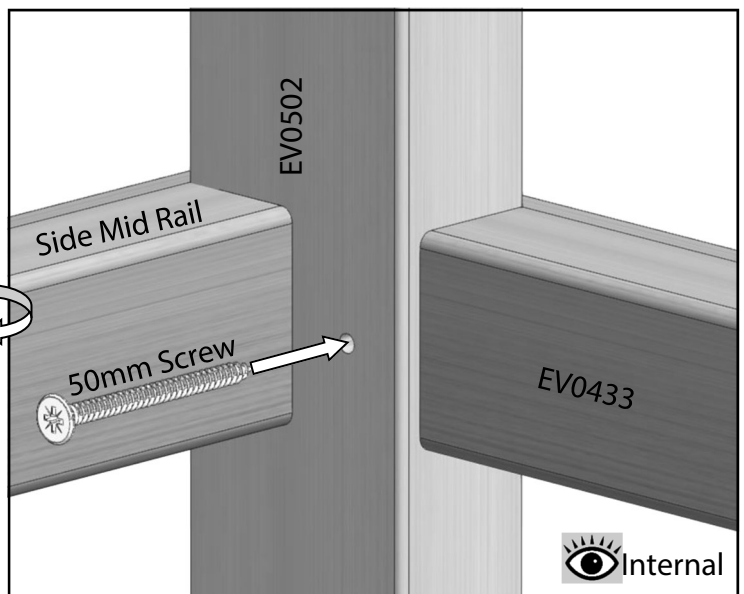
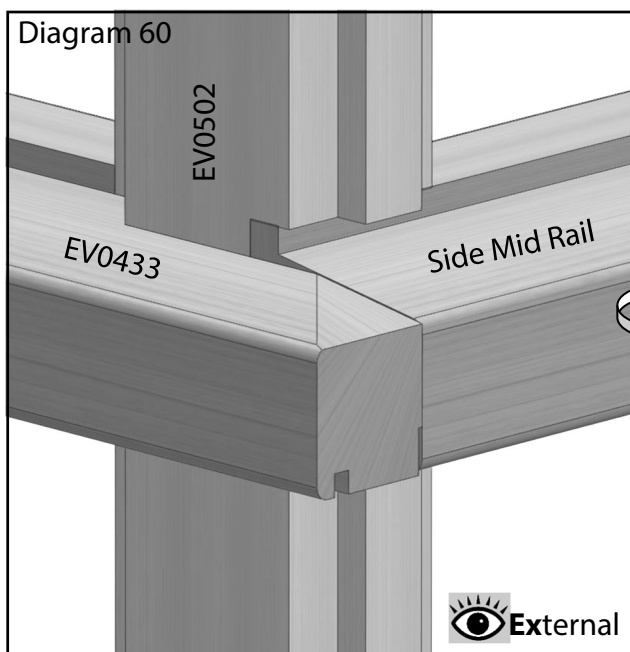

Mid Rail Installation

9 x 12
example

Continue fitting the mid rails working towards the doorway using 50mm and 80mm CSK screws where appropriate. Remember to pilot drill the holes first and to keep all the joints nice and tight.

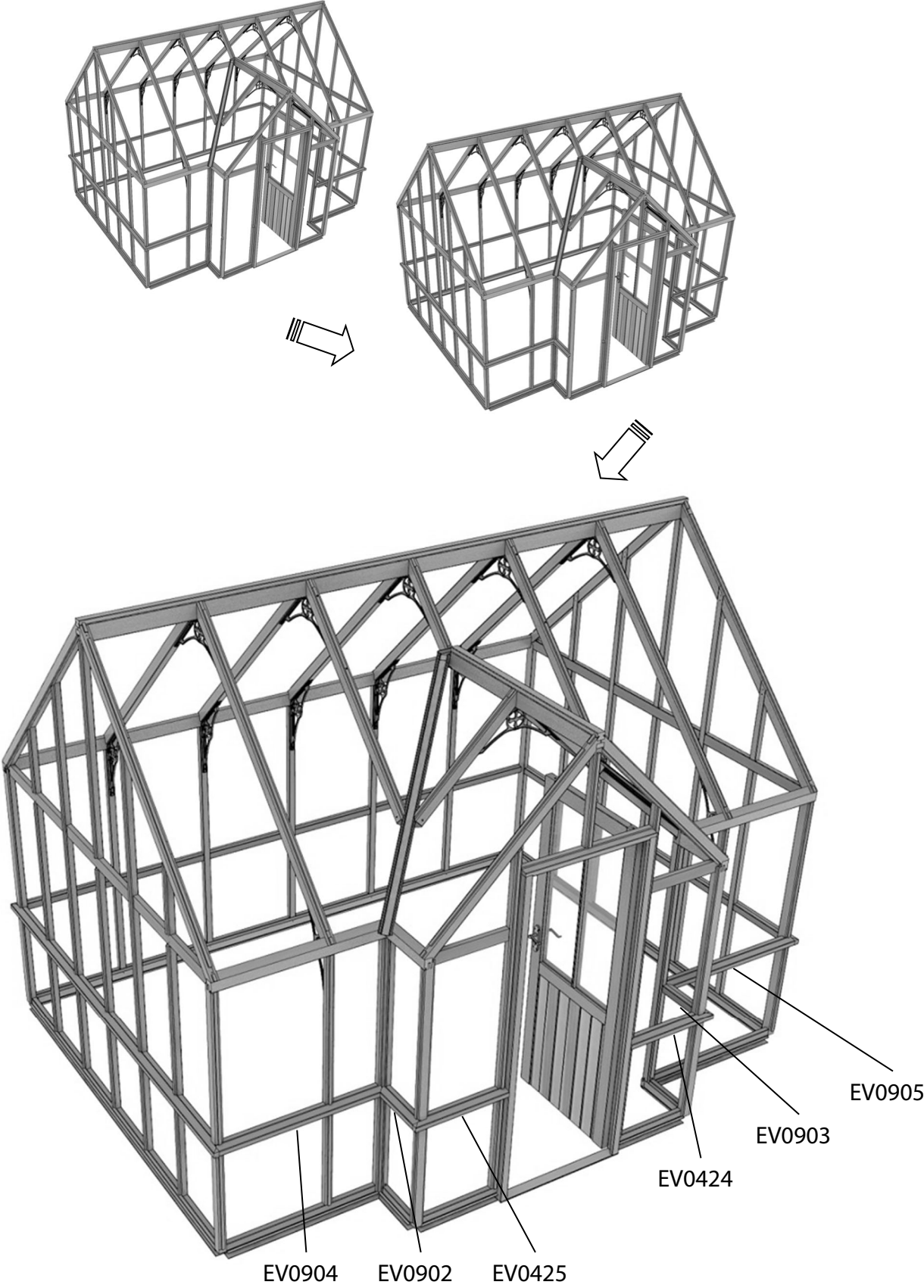

Half Board Installation

You can now insert the wooden half board panels into the greenhouse frame. Start with the first panel on the rear side of the building and work your way round inserting all panels in their various sizes. The cedar capping is fixed with 40mm or 50mm pan head screws (see next page), if it is not windy then you can insert all the boards and then follow around with the capping later.

Each panel should be inserted with the baton closest to one end at the top. Slot the top edge into the mid rail and push the bottom in until it locates with the cill on the inside. The panel should sit flush in the rebate of the glazing bar ready to be retained by the capping.

Half Board Panels				
Part Name	Part Number	Size (mm)	9x8	9x12
Side Panel	EV0550	674 x 610	4	8
Gable Panel	EV0551	674 x 405	12	
Porch Gable Panel	EV0552	674 x 457	2	
Porch Return Panels	EV0542	674 x 295	4	

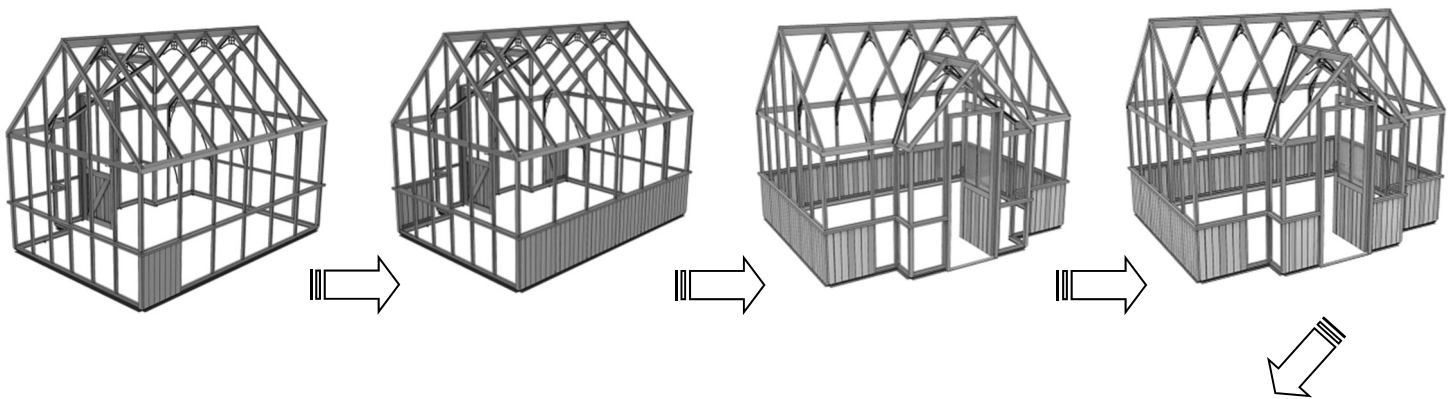

9 x 12
example

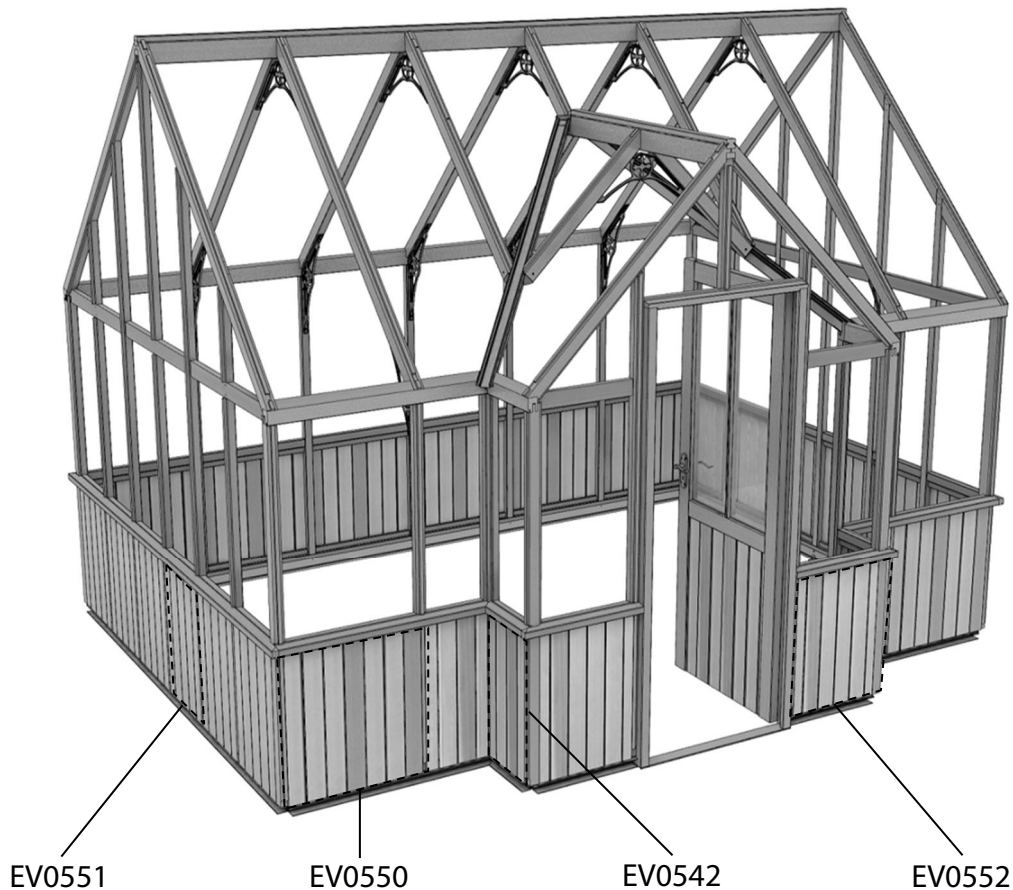



Half Board Installation

The capping comes in three styles see profiles in the table.

The corner capping is wider to cover the gap created by the standard cap on the side of the building. It should be fitted up to this capping but not over it (diagram 61).

Standard and Corner capping utilise 40mm pan head screws (EV0332) and the Porch corner capping needs 50mm pan head screws (EV0367).

Half Board Capping					
Part Name	Part Number	Profile	Size (mm)	9x8	9x12
Standard Capping	EV0598		668	21	25
Corner Capping	EV0599		668	6	
Porch Corner Capping	EV1200		668	2	

9 x 12 example

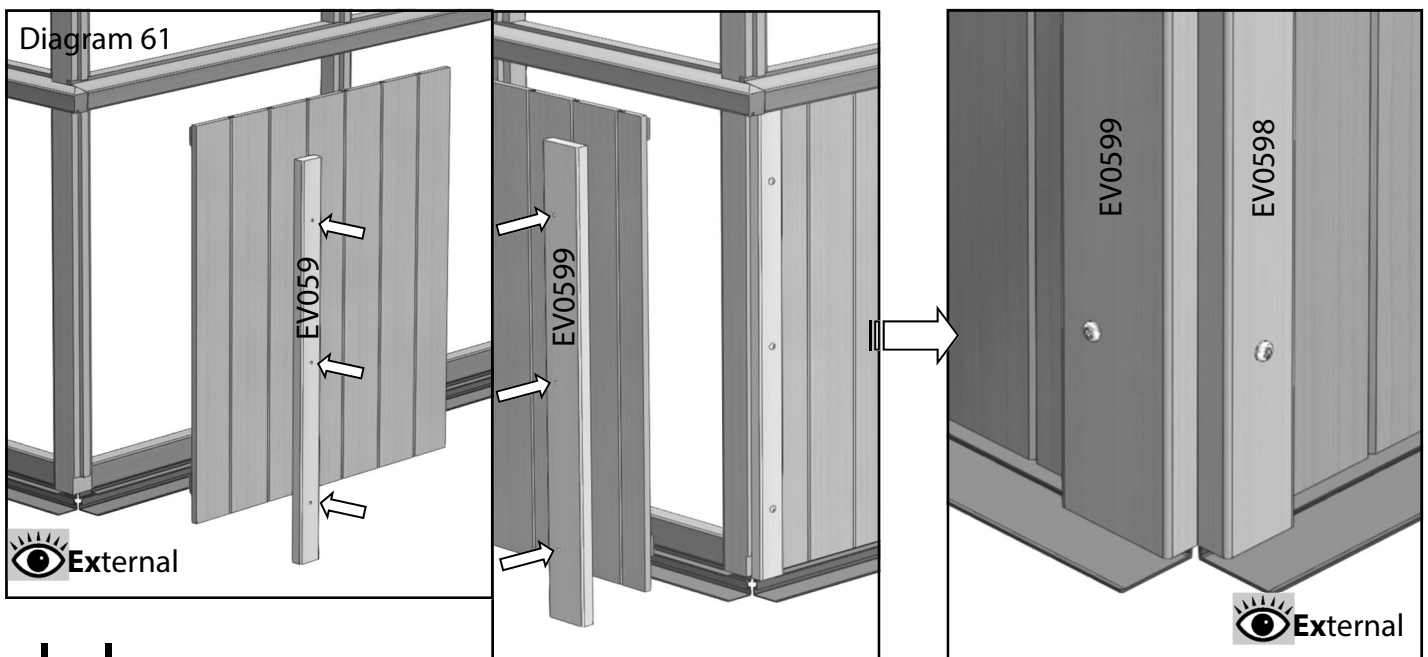
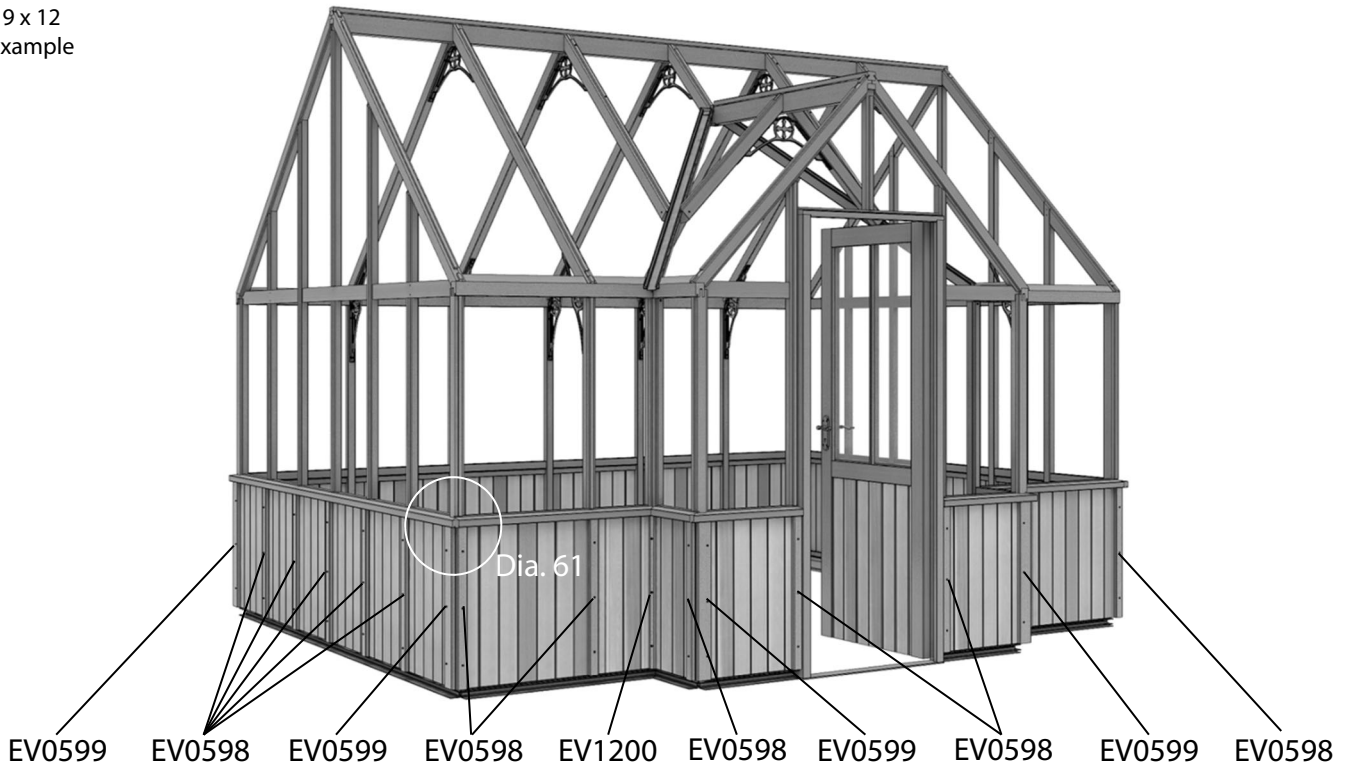

Louvre Assembly

To start building your louvre you first need to assemble the handed sides. Combine the two side sections with the two inserts, see diagram 62 to create the side assemblies.

Trim the rubber seal flush with the ends. Attach the top and bottom of the louvre with the assembly screws in each end. This locates with a screw channel in the side sections (diagrams 62 and 63).

EV0325 - Louvre x 1			
Part Name	Part Number	Size (mm)	Qty
Louvre Top/Bottom	D165M	612	2
Louvre Side Insert	D166M	552	2
Louvre Side	D168LM	552	1
Louvre Side (handle)	D168RM	552	1
Assembly Screw	02-1864	n/a	4
Louvre Glass	D729TG	100 x 525	6

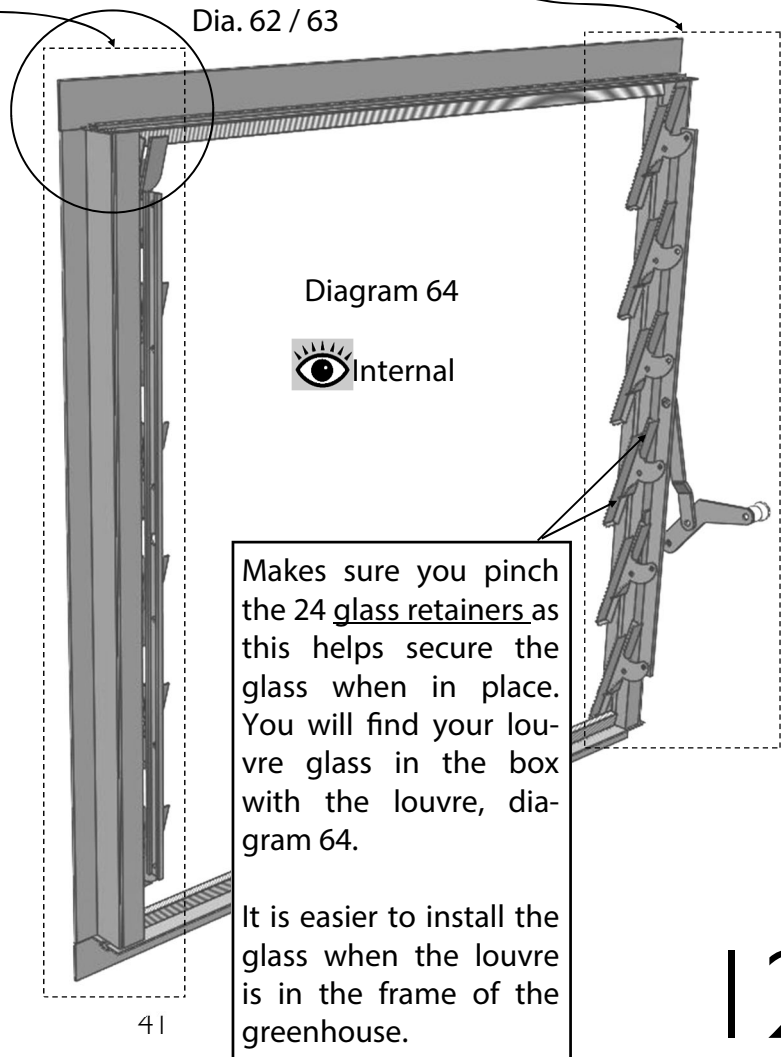
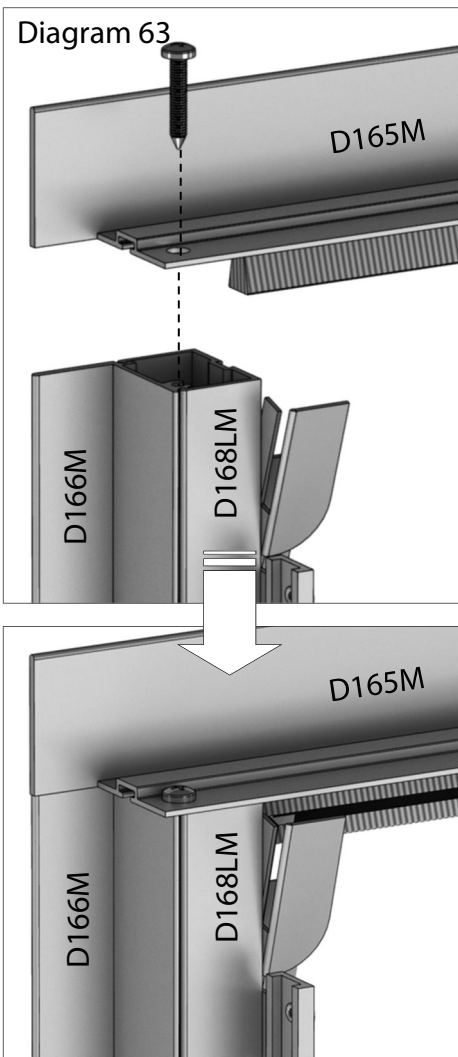
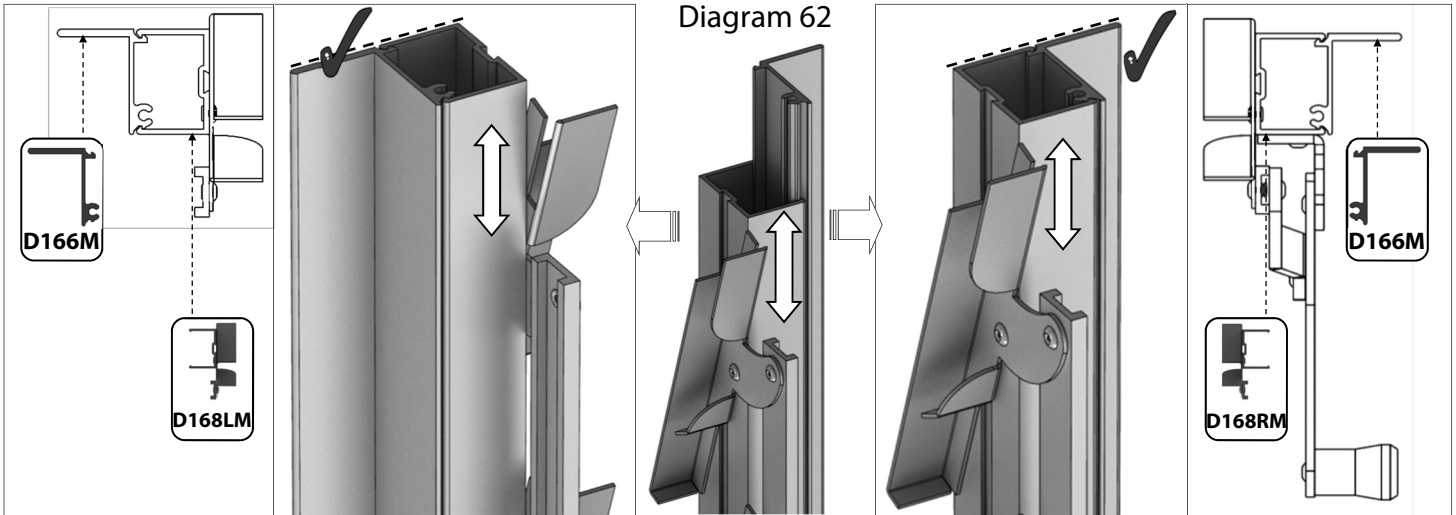

Glazing *Standard cedar capping or the upgrade aluminium capping?*

If you have the Aluminium capping you need to slide the glazing rubber into channels on the back of the capping (see right), this includes the porch internal corner capping (EV1180M). Use a Stanley knife or scissors to cut to length, it is best to use a complete length per side.

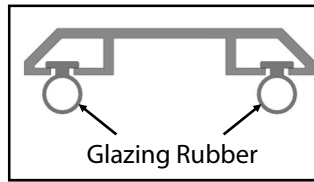

If you have the cedar capping you can pre load each strip with the 25mm Pan Head screws (EV0331). Also before you install each pane you need to run a thin bead of silicone up each glazing bar (no greater than 5mm is needed).

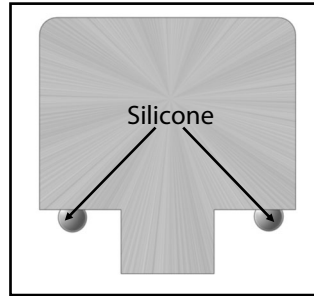

All of the capping is pre-cut to length, so sort through it placing the capping around the building close to where you can reach it.

Glass Size	Code	98	912
A (see diag.)	EV405X450X45	4	
B (see diag.)	EV405X875X470	4	
C (see diag.)	EV405X1298X893	4	
D (see diag.)	EV457X496X39	2	
E (see diag.)	EV405X540X135	2	
F (see diag.)	EV610X1345X838	2	
G (see diag.)	EV556X810X23	2	
H (see diag.)	EV610X1335X545	2	
J (see diag.)	EV610X1256X749	2	
295x916	EV295X916	4	
405x916	EV405X916	12	
457x916	EV457X916	2	
610x916	EV610X916	2	6
610x153	610X153	4	
525x100	D729TG	12	
610x610	610X610	2	4
610x1256	EV610X1256	-	2
610x1873	EV610X1873	4	6
284x1050	VICG0005 (pre-installed)	2	
SEPERATORS	ROSPES (610mm)	18	
GLASS STOPS	EV0313M (aluminium)	16	24
RUBBER?	D227 = 10meters	130m	160m

NB: Capping lists can be found at the rear of this book. Use the lengths to help identify each part.

NB: Before you start glazing check the squareness of the greenhouse, installing a large roof pane will often tell you more than a spirit level.

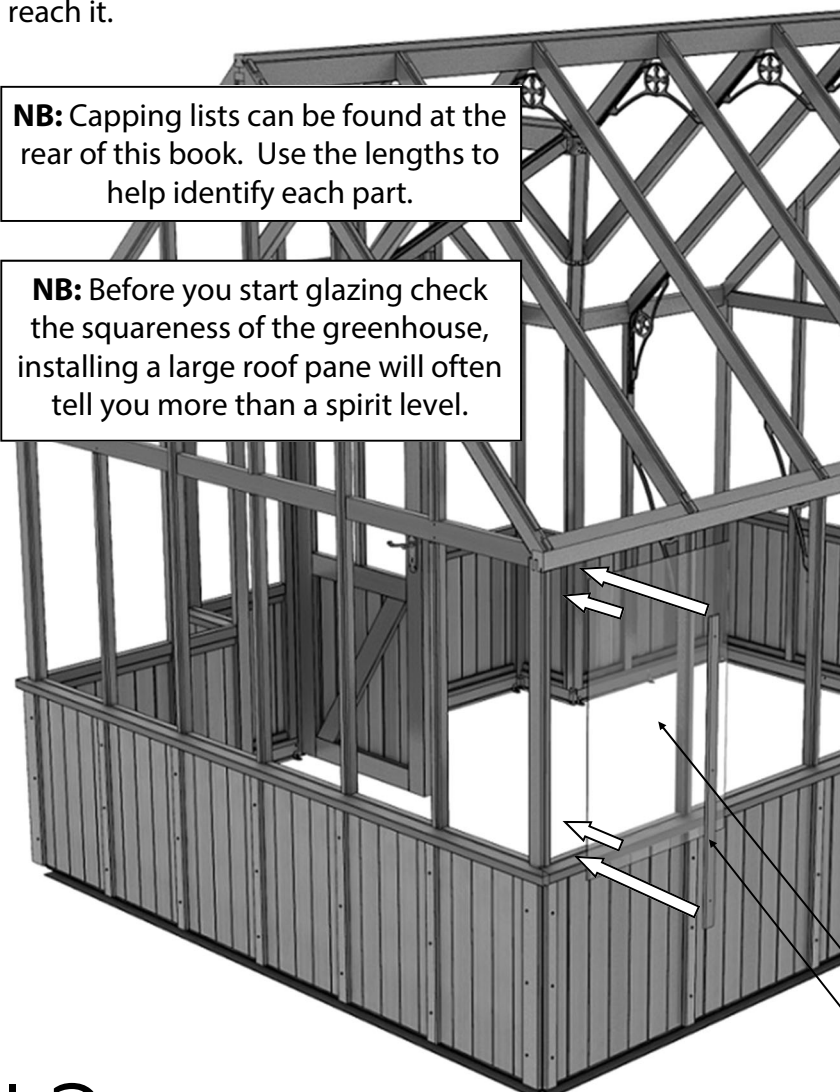

IMPORTANT:

It is advisable to glaze the porch roof panes **G** and **H** first whilst the building has maximum movement in it, they are the panes which tend to be hardest to fit.

It is then a good idea to fit a rear side pane to check that the structure is vertical and a large roof pane to check that the building is square. The roof sheets which reach down to the eaves bars need to be retained by a pair of aluminium glass stops (EV0313M), see next pages.

Your porch **gutters** need to be fitted prior to fitting panes **F** and **J** but after all the side panes have been installed. The roof glass canopies the fixing points on some of the gutter sections so the gutters need to be fitted first.

610 x 916
Glazing Bar
Capping

Slide the glass into the groove of the eaves bar and rest it on the cedar mid rail.

Glazing

Note: All channels in the aluminium capping should have rubber inserted, even if it is going onto the timber.

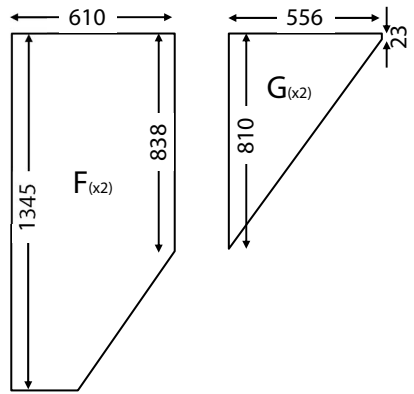
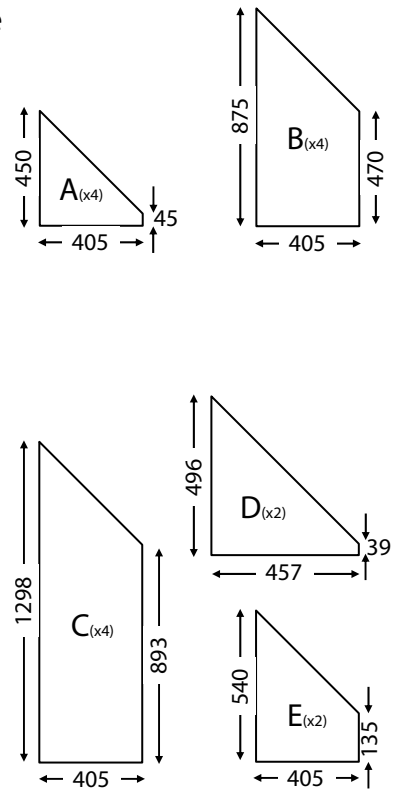
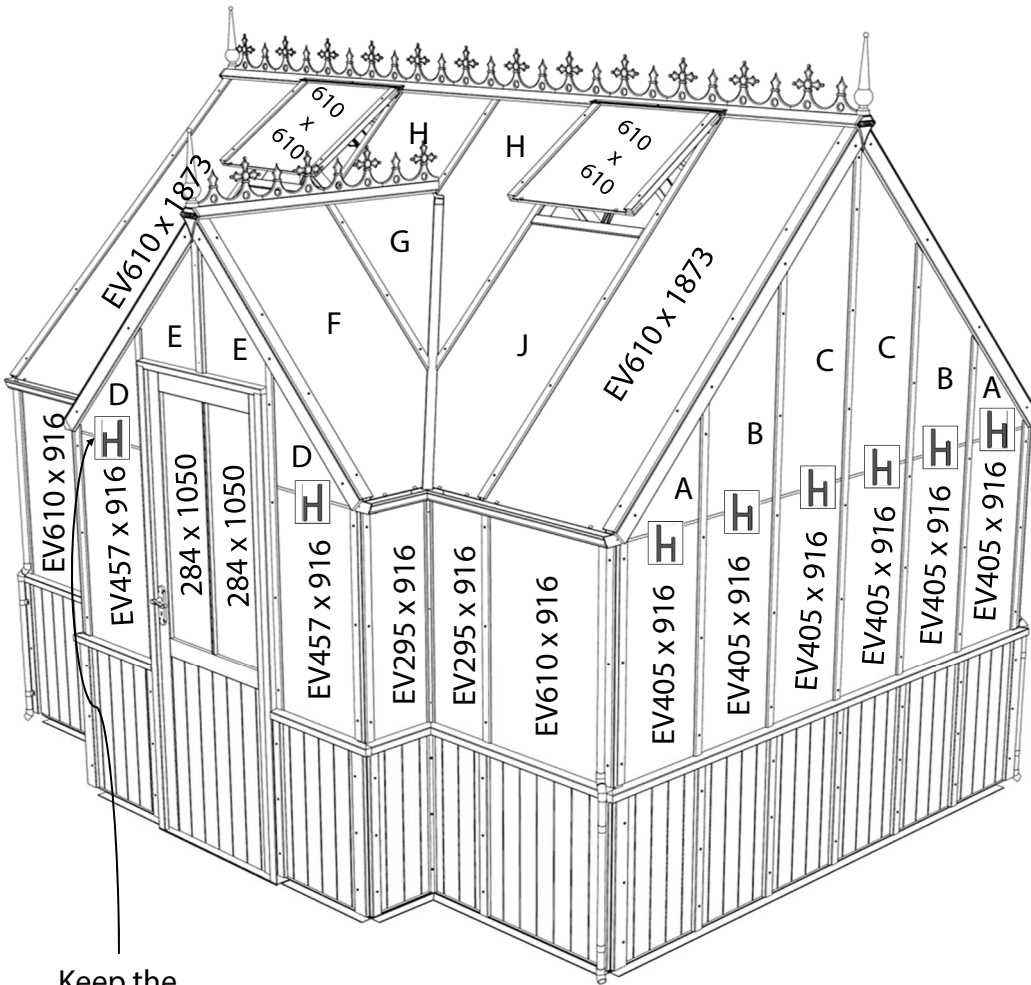

Keep the short flange pointing upwards on the outside.

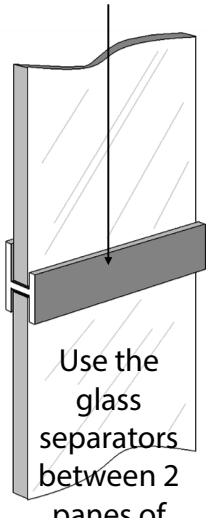

The louvre can replace any of the EV610 x 916 panes.

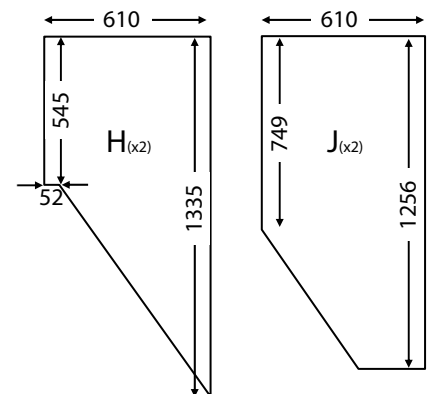
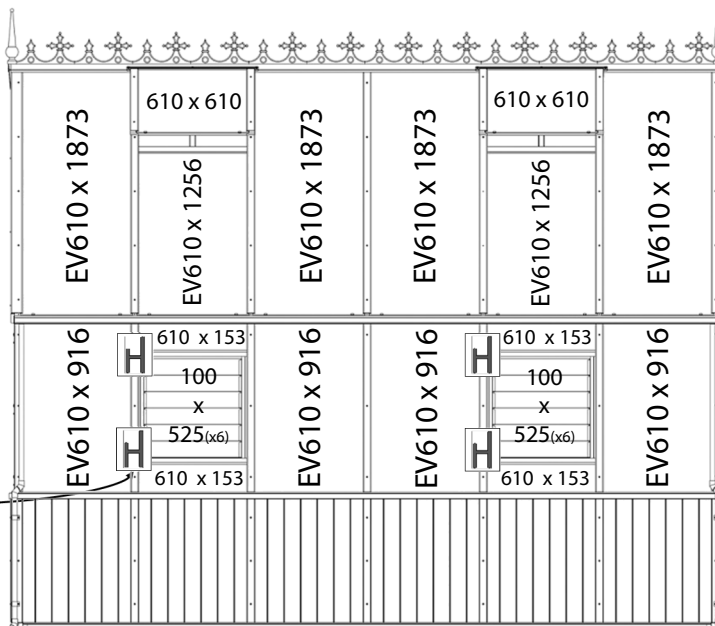

Use the glass separators between 2 panes of glass and above and below the louvre

Glazing (part 1)

You need to decide where in the building you are having your louvers. Below is an example of how it might be fitted. The louvre can replace any of the 610 x 916 panes, but make sure the handle operates and that there is no interference with the glass in the location that you choose. Make sure you fit it the right way up (the handle is always on the right standing on the inside). Once in position fix the next piece of capping. This has now fully secured the previous pane and partially secured the current one.

Keep working round the building in the same direction, fitting louvres when needed. If you are right handed it is easiest to work left to right and vice versa!

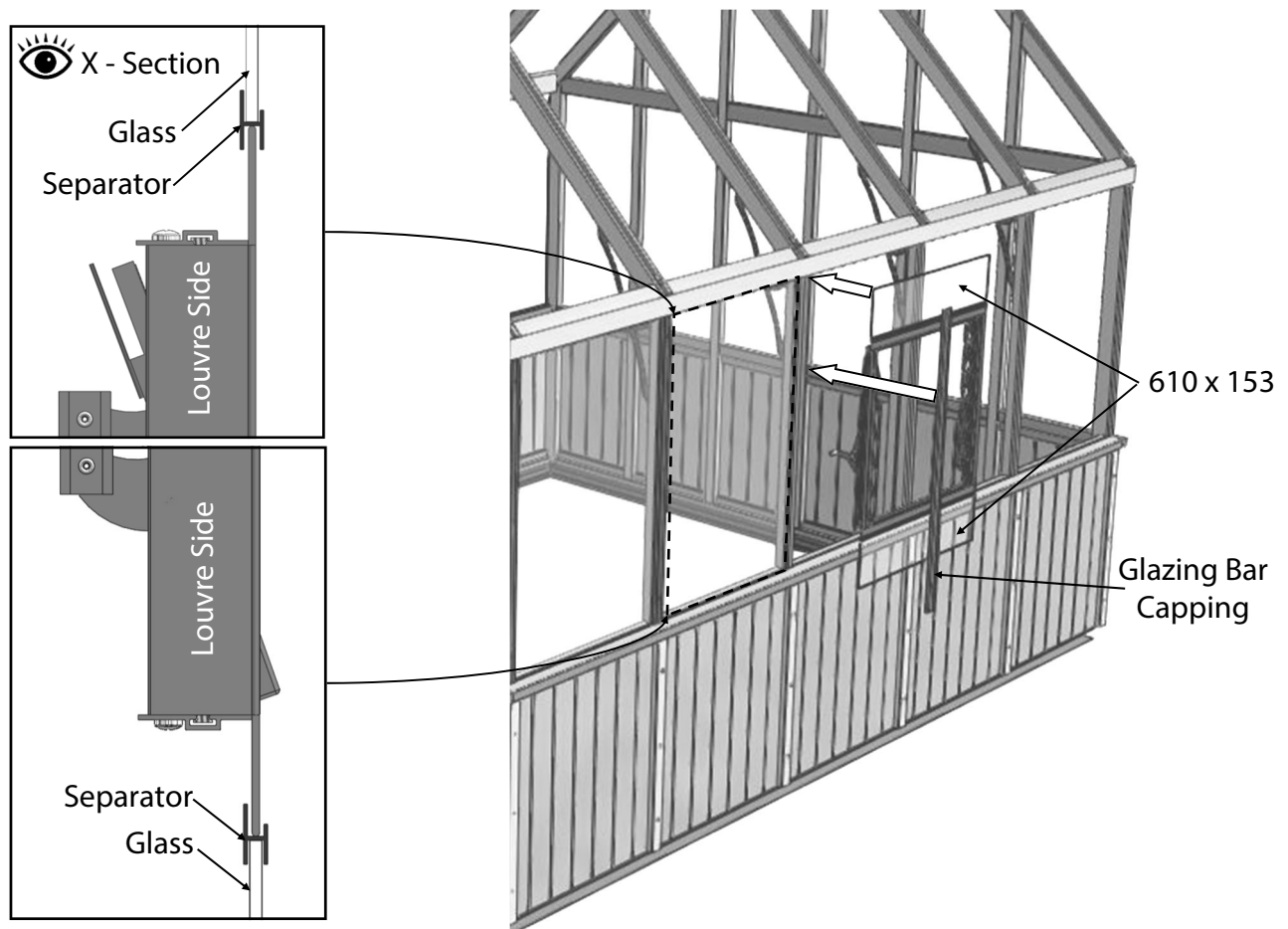

Install the end and porch gable glass in the same method as the side glass, the only difference is you have to stack the shaped panes on top using the black plastic 610mm (cut to the width of your glass) glass separators (ROSEPS). Make sure you have all the glass to hand when you are glazing these sections. It is also a good idea to have an extra pair of hands to hold glass in place while you get the next section of glass ready. Always keep the glazing capping flush with the bottom of the glass.

Once the vertical capping is on you can fit the roof corner cloaking strips (diagram 65). These are handed (EV0524 left, EV0523 right) as they have glazing beads already attached to them to secure the shaped panes along the top edge, so make sure you have the correct one. Once all the roof corner cloaking strips have been installed run a bead of silicone all the way down the joint between itself and the roof corner bars (diagram 66).

Glazing (part 1)

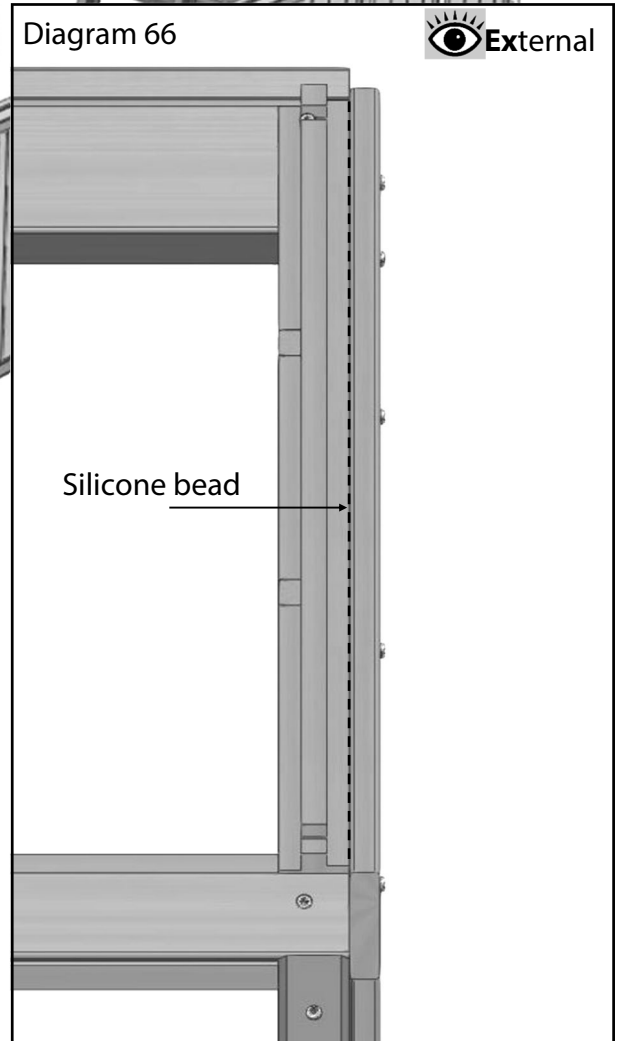
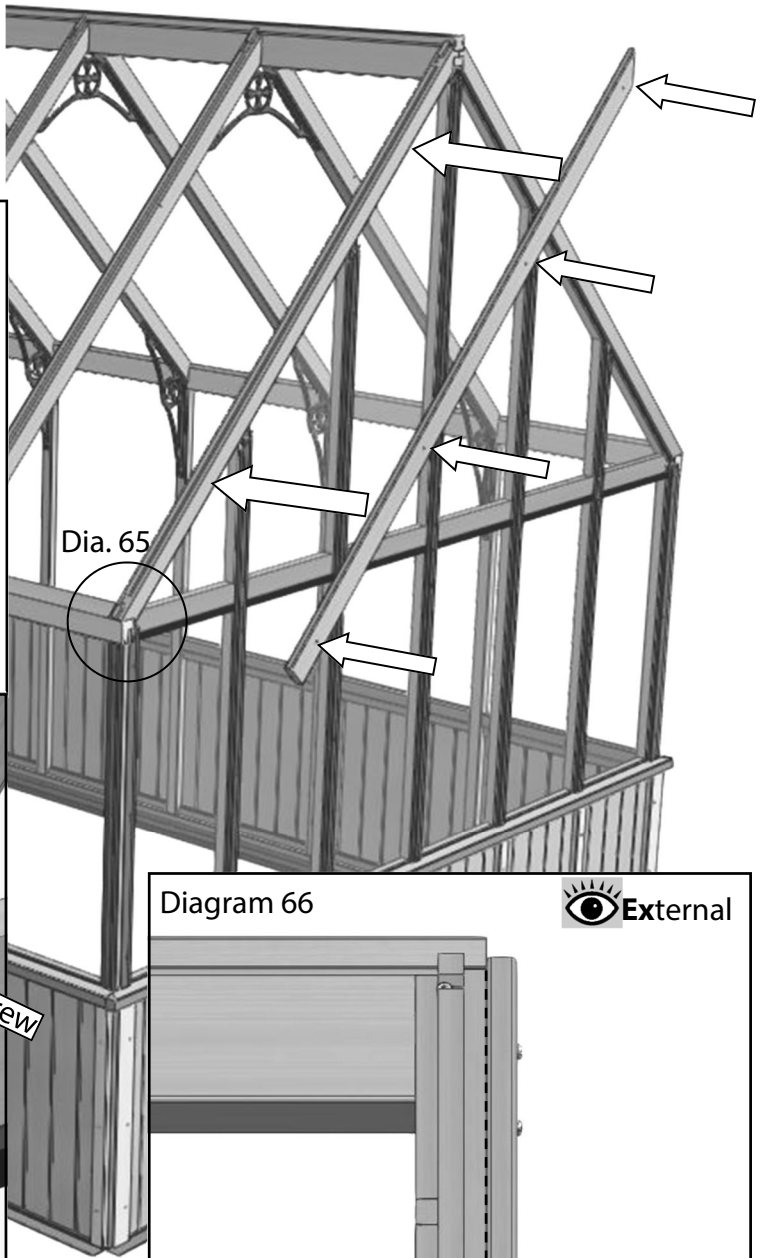
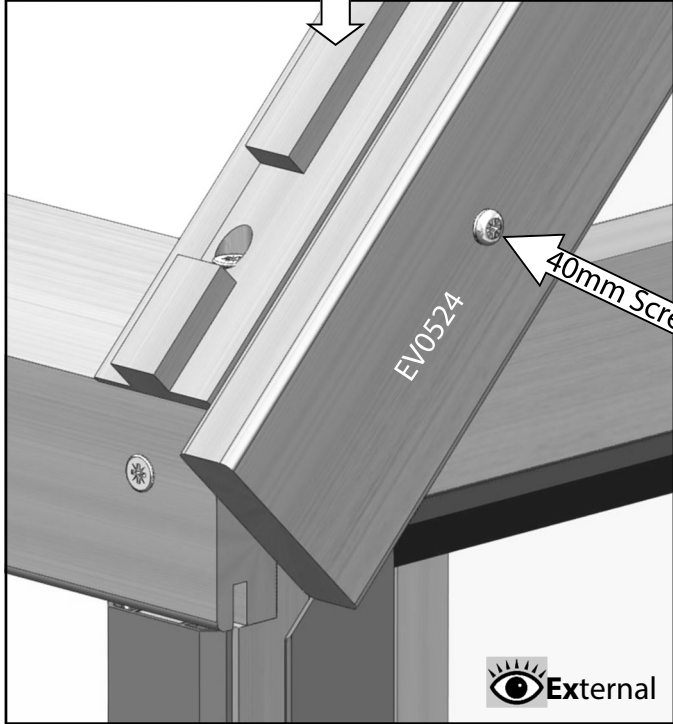
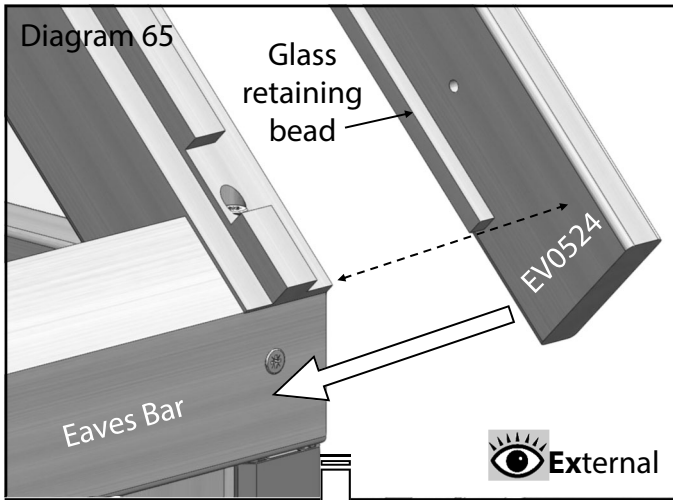

Louvre Glazing

If you haven't already done so you could now install the louvre glass (diagram 67).

Make sure the tabs on the glass retainers are pinched slightly so they hold the glass tight. Standing on the inside of the building slot the first louvre slat in until it hits the bottom tab of the retainer. Repeat this until all are installed.

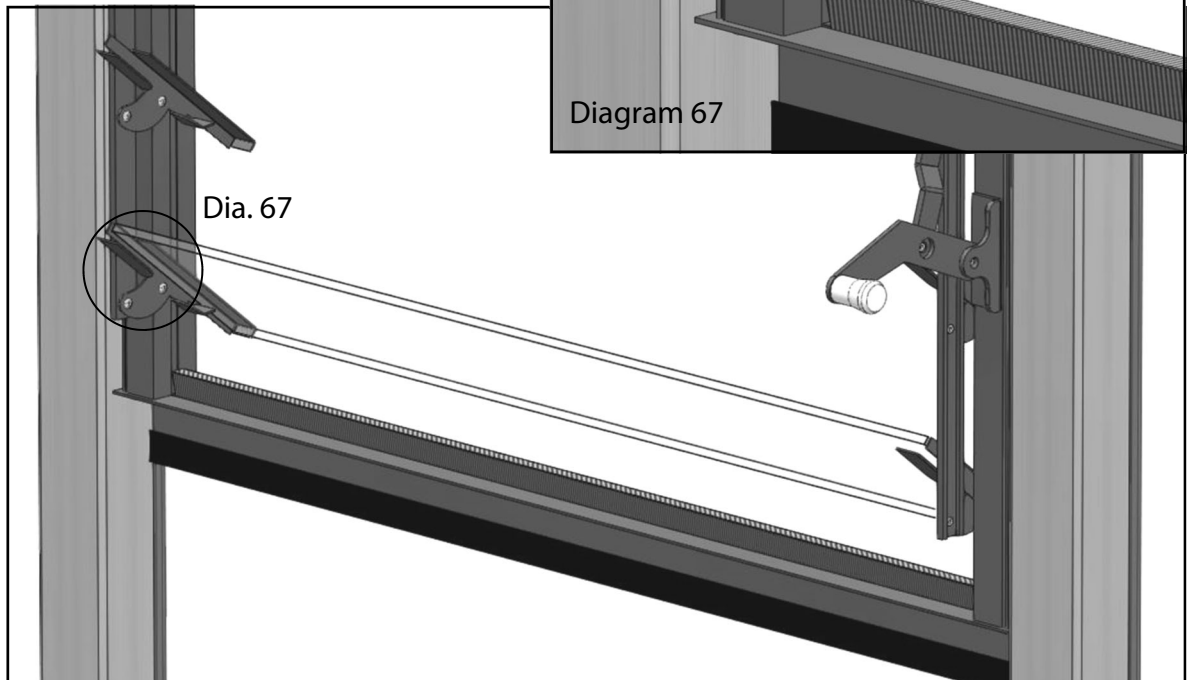
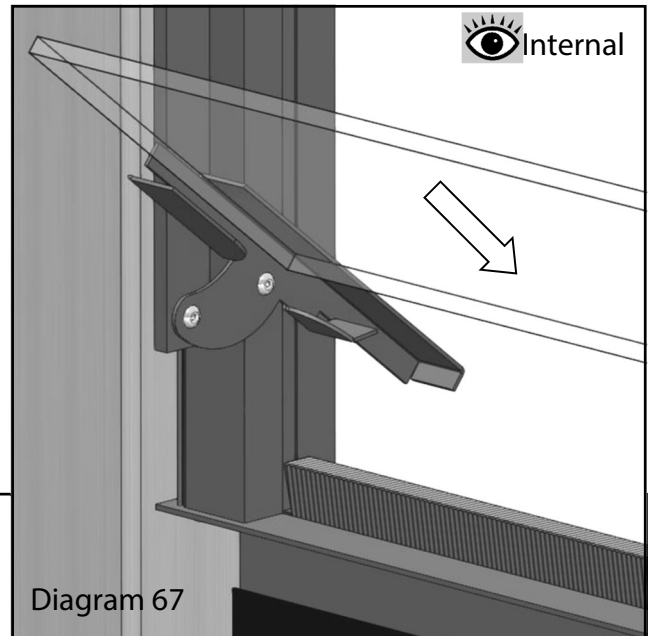

13

Gutter and Downpipe Installation

With help position your gutter on the rear side face of the eaves bar, this should be the same length as the eaves bar and fit between the ends of the roof corner bars. Fix it in place with 25mm Pan Head screws, diagram 68. The top edge of the gutter parts should not come above the angled part of the eaves bars else glass interference will occur.

Fit the plastic pipe insert (D201) into the ends of the gutter for your down pipe to run out of (diagram 69). Use a small amount of silicone to seal this in place.

Gutter Parts			
Part Name	Part Number	9x8	9x12
Gutter 8' long	EV0622M	1	-
Gutter 12' long	EV0624M	-	1
Porch Gutter 1' Long LH	EV1163M	2	1
Porch Gutter 1' Long RH	EV1164M	2	1
Porch Gutter 3' Long LH	EV1165M	-	1
Porch Gutter 3' Long RH	EV1166M	-	1
Porch Gutter Insert	EV1168	2	
Stop end RH	EV0535M	3	
Stop end LH	EV0536M	3	
Downpipe Bracket	EV0740M	8	
Downpipe Outlet	D201	4	
Downpipe Shoe	D207	12	
Downpipe	D211	4	
Rubber Blank	D214	2	
Clear Silicone	02-1356	3	4

14

Gutter and Downpipe Installation

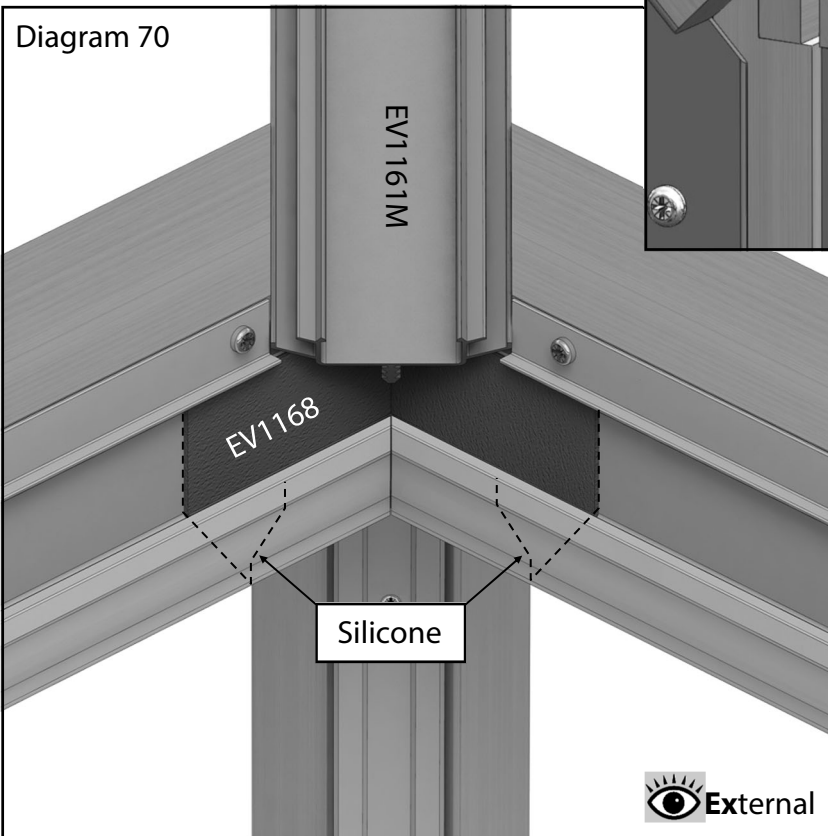
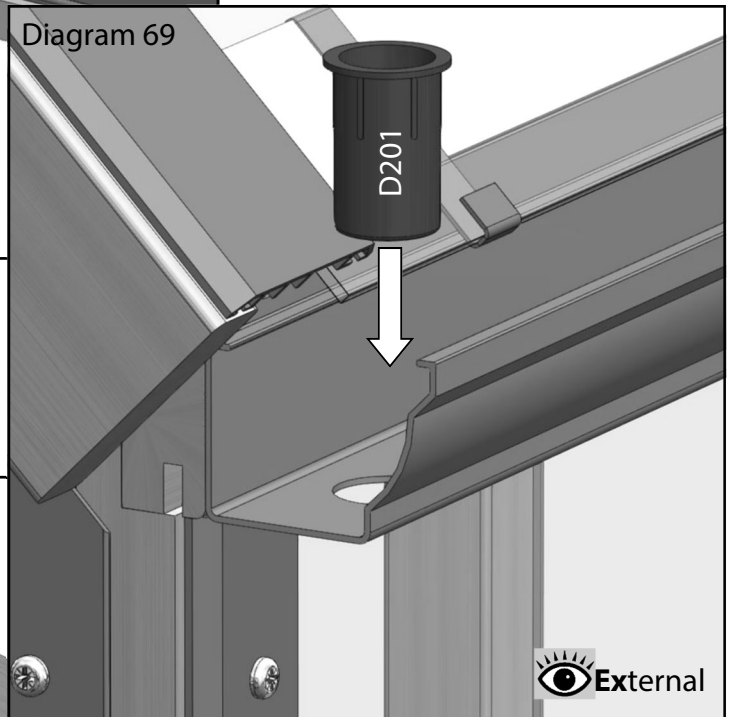
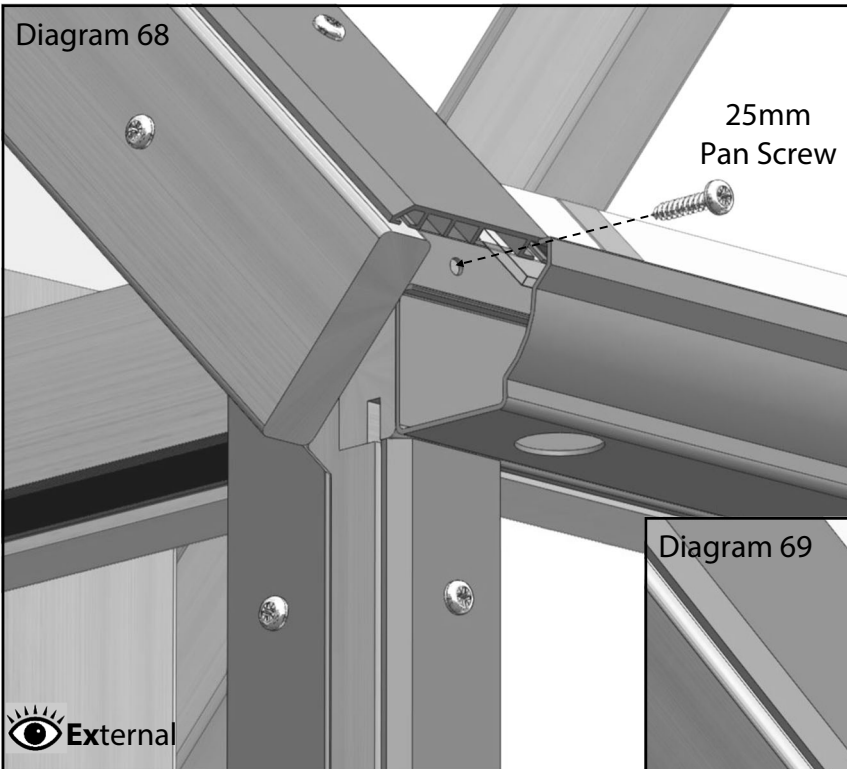

The handed porch gutters are also secured with 25mm pan heads. They have a flexible black plastic insert (EV1168) in each return corner which needs to be siliconed into place to stop the gutter joint from leaking (diagram 70). You may find it easier to pre-assemble each L-shaped handed gutter section on your work bench and then fit the completed section whole.

Gutter and Downpipe Installation

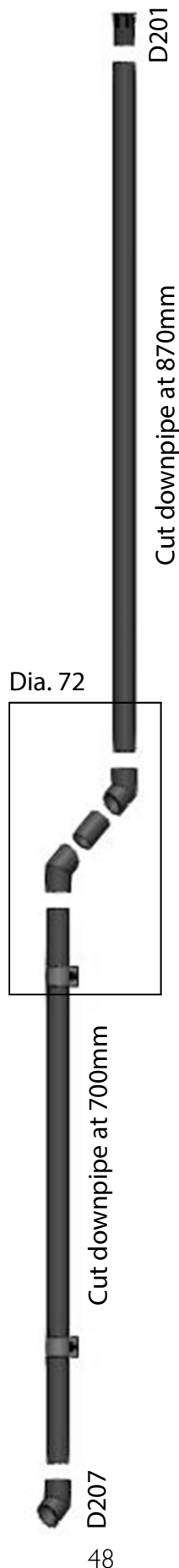
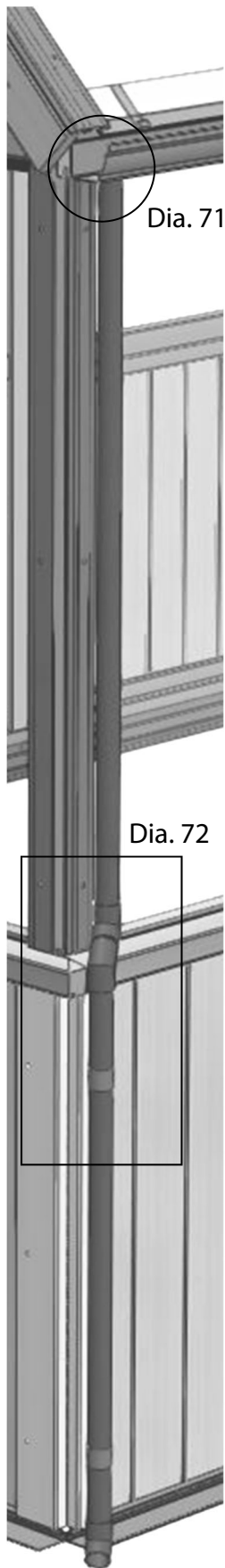

To install the downpipes straight to the floor cut the pipe as per the diagrams below. Use a small amount of silicone at each joint. The brackets can share the same hole as the capping for the panels. Use two M6 nuts as washers to space the brackets out so the pipe run vertical.

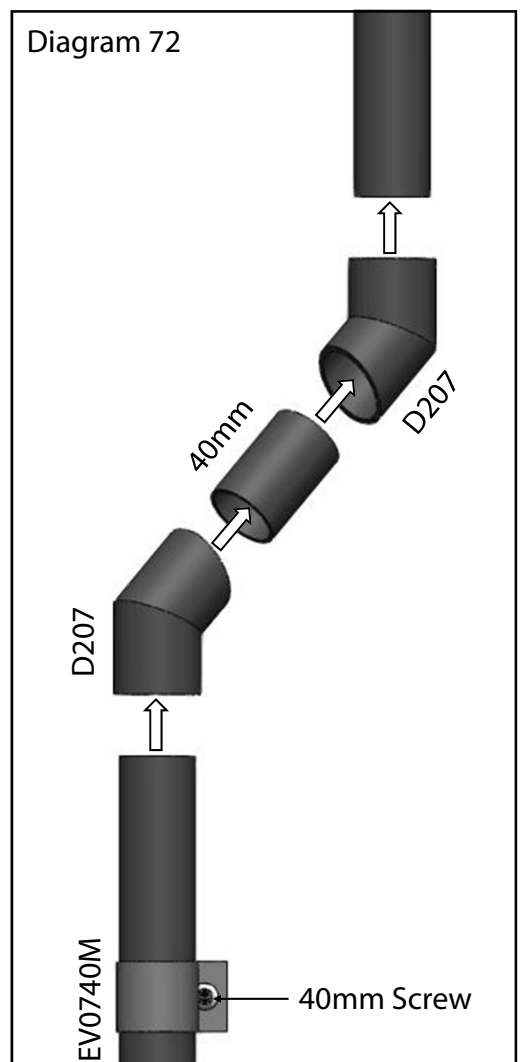
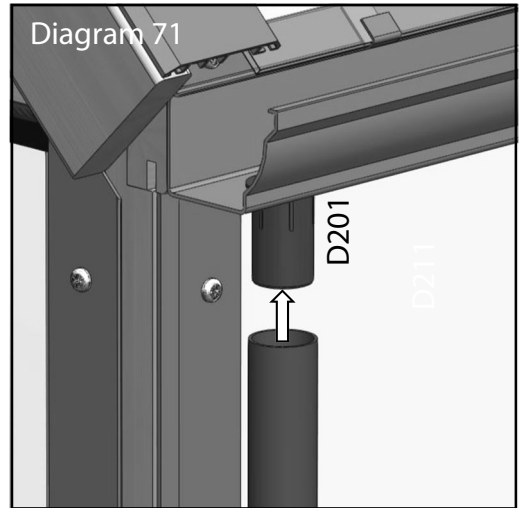

Gutter and Downpipe Installation

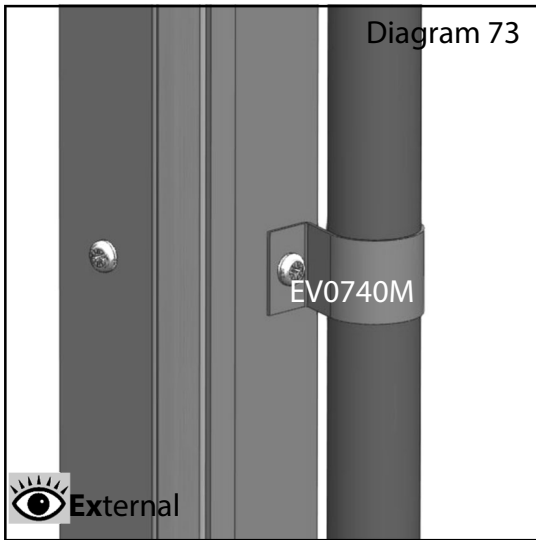

If you want to connect the pipe to a waterbutt cut the pipe appropriately and simply use the D207 joints to divert the pipe. Its likely you will need to fix the downpipe brackets higher up, again try to use a standard capping screw location (diagram 73). If you have the aluminium capping you may find you wish to use an M6 nut to space the bracket out so the pipe runs more inline with the greenhouse frame.

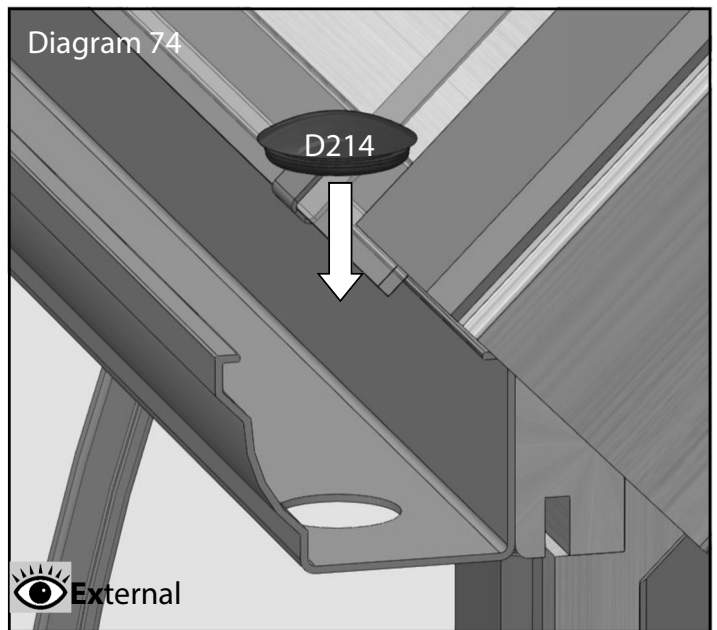

Pop the small rubber blank (D214) into the hole that is not required (diagram 74).

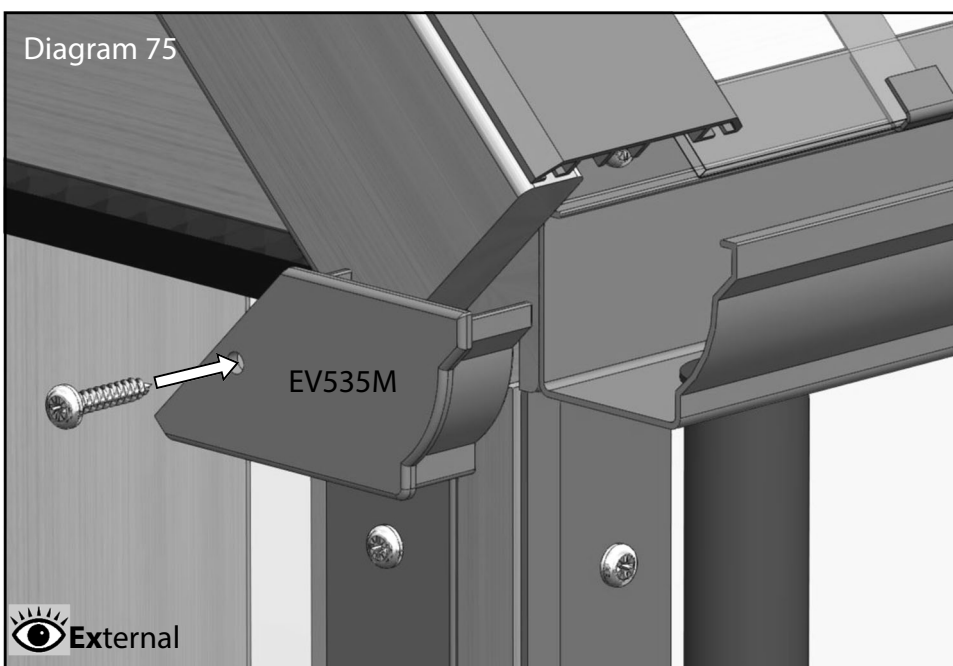

You can now fit the cast aluminium end stops (diagram 75). These will need a good amount of silicone applied to create the seal to the gutter, any excess should be removed once in place. Fix with one 25mm Pan Head screw.

Glazing (part 2)

Next you need to decide on the location of your roof vents. These can NOT be fitted side by side. Once you have decided this start by installing the glass that goes underneath the vents. Use 2 of the glass stops (EV0313M) per pane diagram 76.

There are 2 grooves in the slam rail, the one nearest the edge should be used for the aluminium capping and the one nearer the middle for the cedar capping.

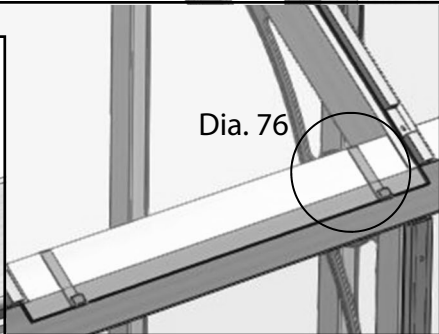
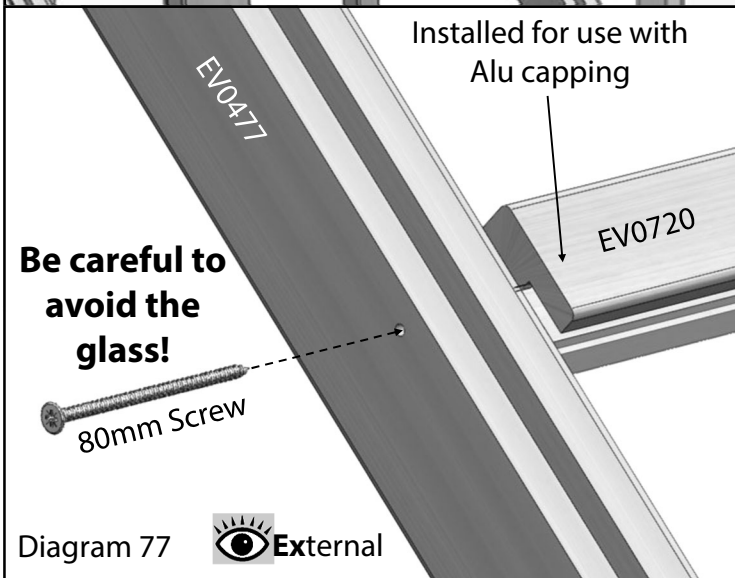
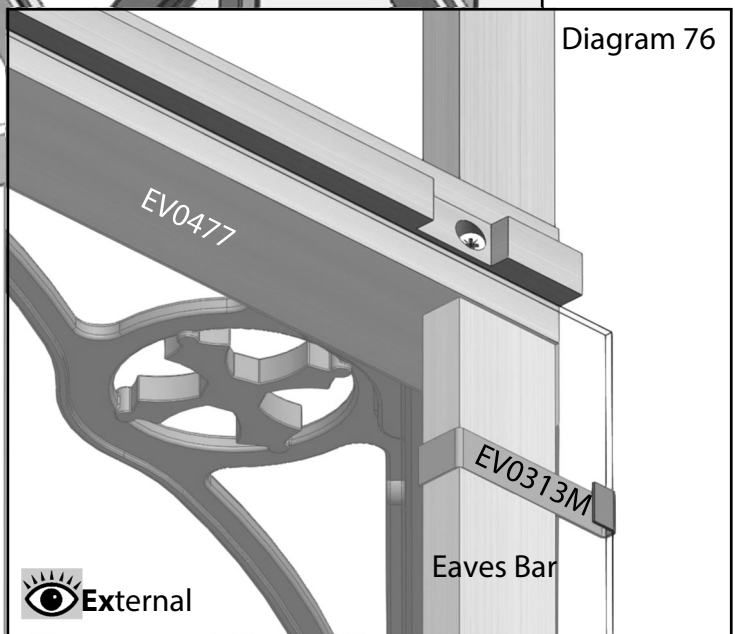
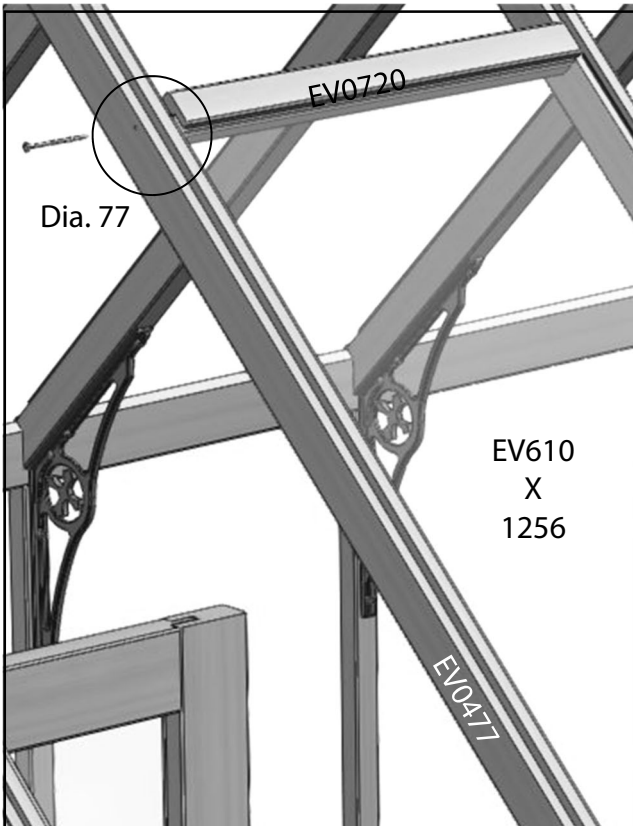
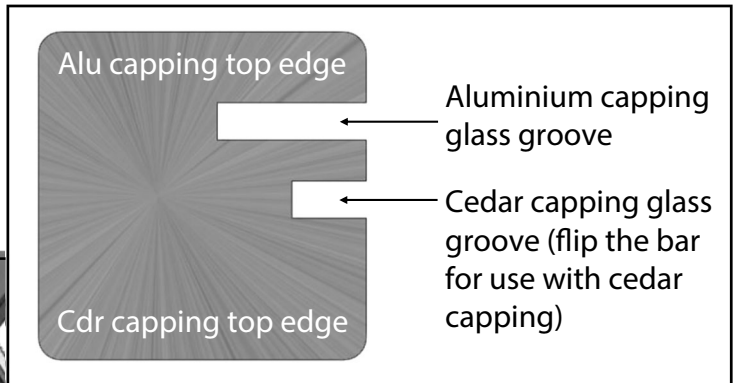

Then position the slam rail (EV0720) on top of this pane of glass. This should be fixed with a 80mm screw, diagram 77 (remember to pilot drill first), sink the head slightly into the timber for a neat finish.

Glazing (part 2)

Now complete the glazing by fitting the roof panes. Slide these all the way up the glazing bars, making sure they tuck into the groove in the ridge. Slot 2 of the glass stops (diagrams 78 and 79) on and lower the pane down onto the eaves bar. This will now support itself while you fix the capping in place. As with the sides work in a loop around the building. The capping for the roof corners is wider than normal to cover the join of the cover strip to the roof corner glazing bar. The capping should also be fitted flush with the bottom edge of the glass at the eaves.

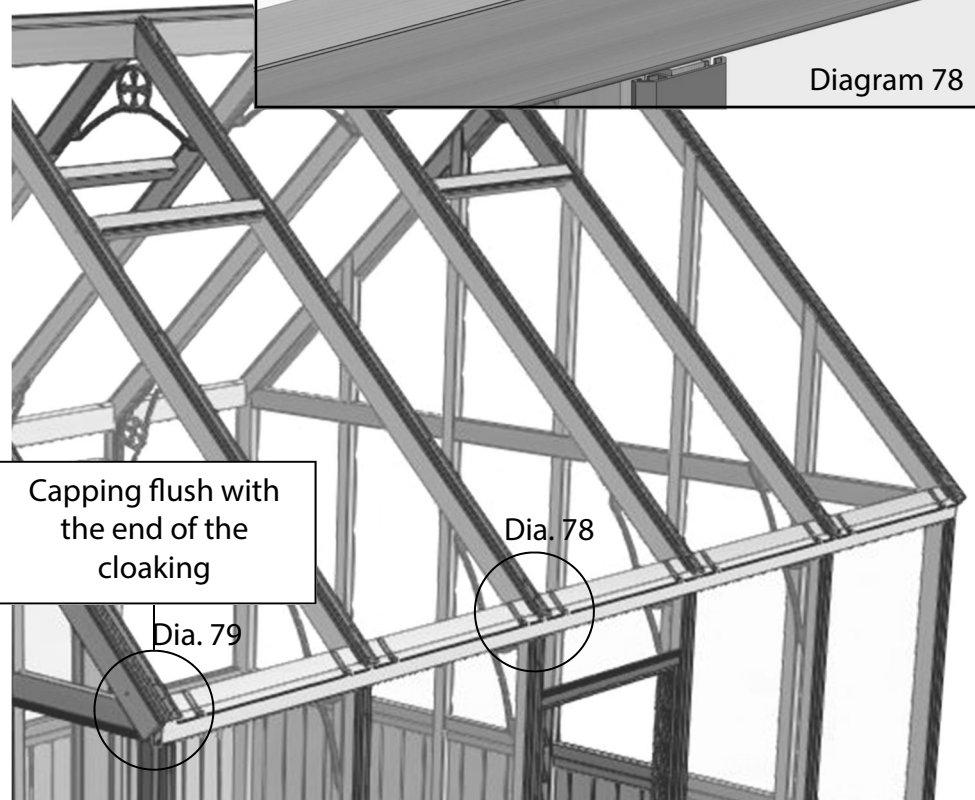
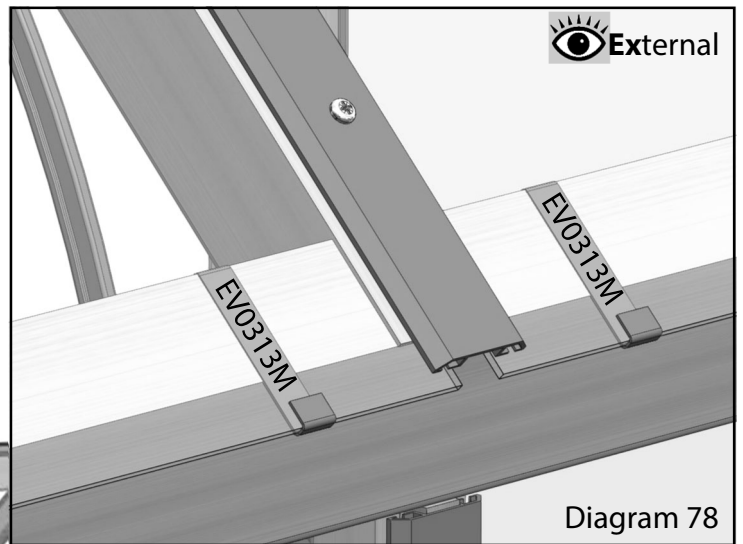

The corner capping should overlap onto the cloaking strip to seal the joint between the cloaking strip and the roof corner bar.

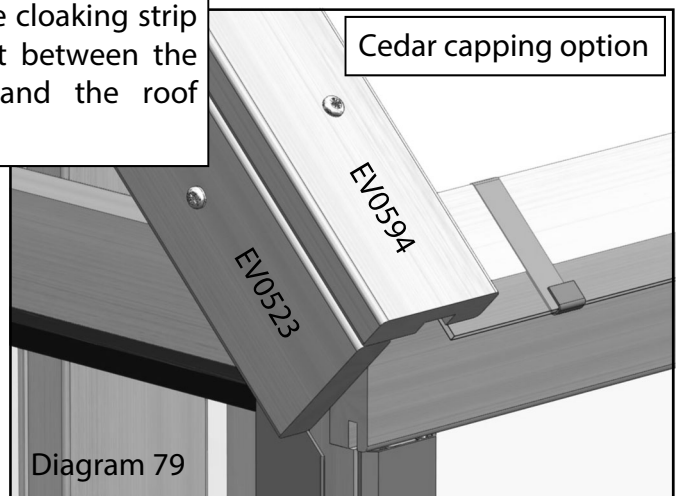
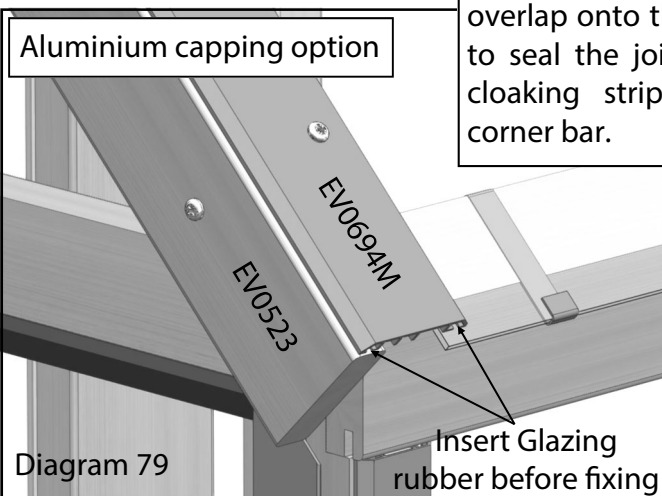

IMPORTANT: Use **25mm countersunk screws** where a vent is to be used so the head of the screw doesn't prevent the vent from closing properly.

Glazing (part 2)

Once all the glazing has been finished you can install the ridge cover cap. This is a universal part that can be used with either cedar or aluminium capping. Simply place the cap on the ridge flush with the faces of the fascia boards and fix with (EV0363) washers and 40mm pan head screws.

Repeat the same procedure with the porch ridge cover EV1174M keeping it flush to the front face.

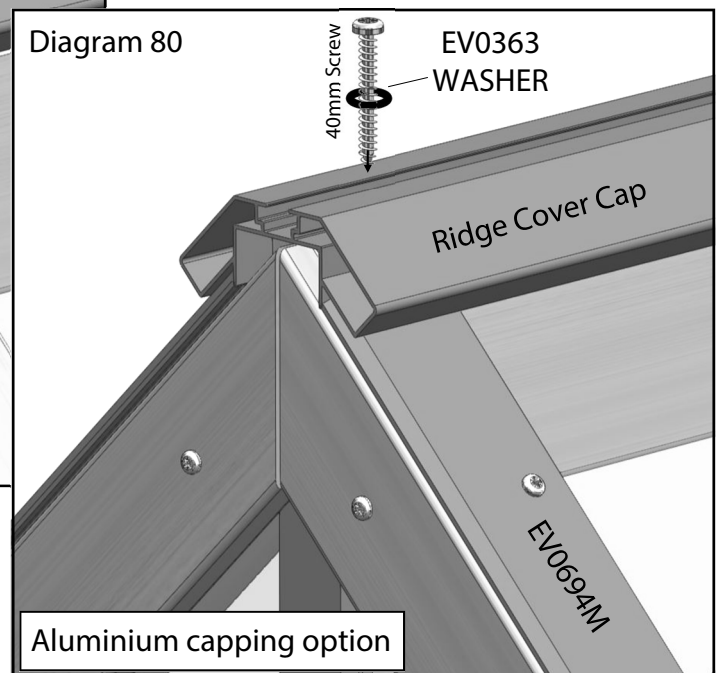
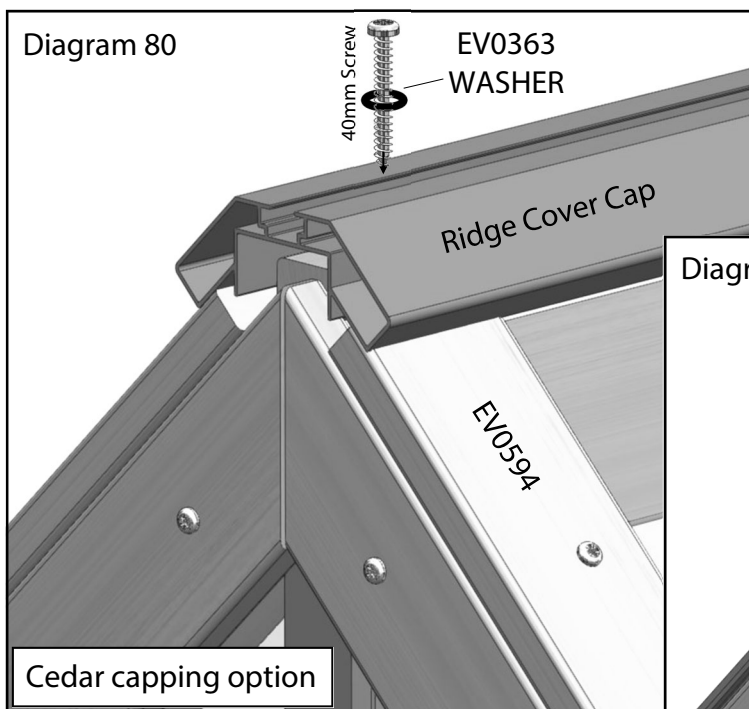

Roof Vent Installation

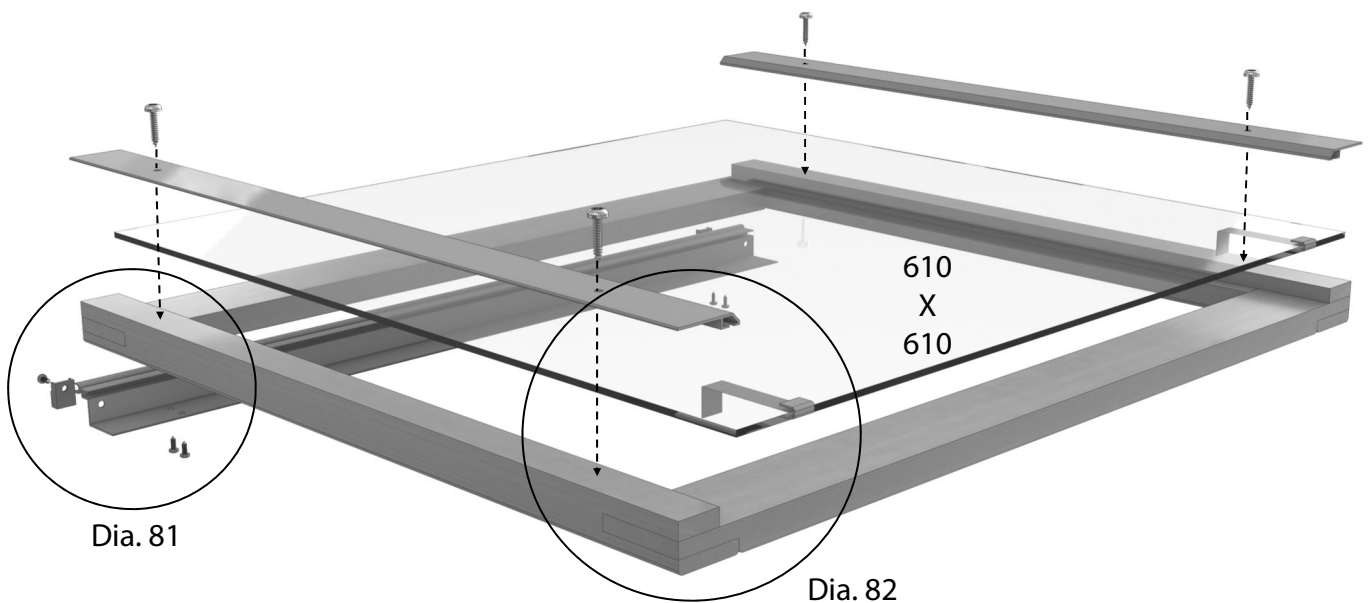

Take the vent frame that is ready assembled and fix the vent hinge to one end through the 4 pre drilled holes using the 20mm screws, diagram 81. Once this is in place fix the plastic vent filler (EV0323) also with a 20mm screws, its is **important** to make a pilot hole before fixing the plastic filler to prevent splitting.

Now take a 610mm x 610mm pane of glass and locate this in the vent hinge. Before lowering this down completely slot the glass stops onto the open edge.

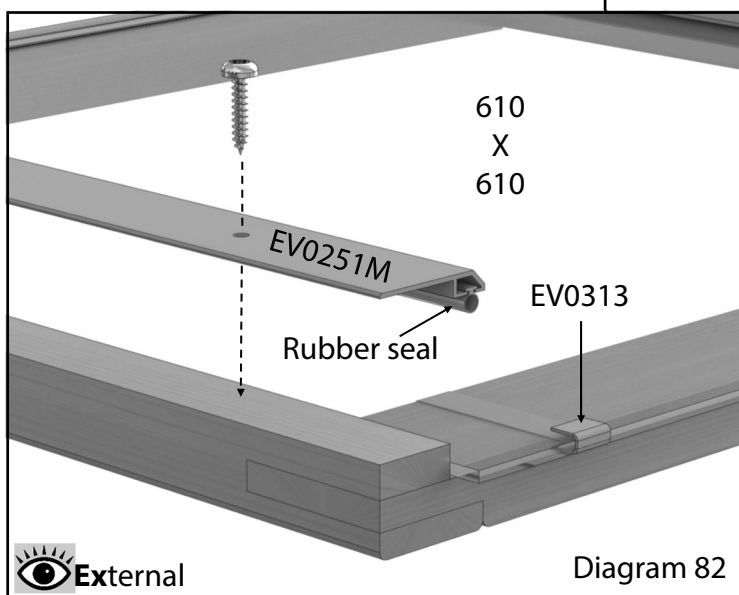
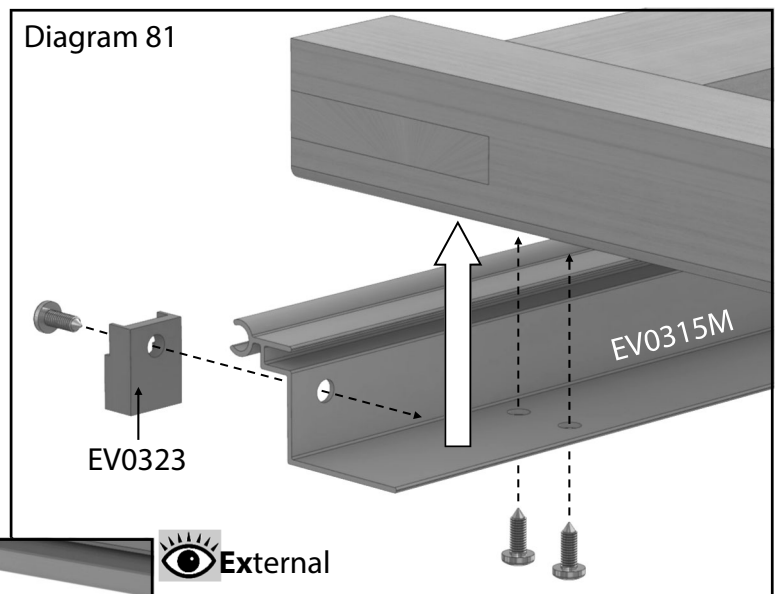

When in position you can fix the glass in place with the vent capping (either cedar or aluminium) using the 25mm Pan Head screws, diagram 82. Remember if you are using the aluminium capping system you will need to insert the rubber seal before fixing it in place.

(Cedar capping part number: EV0151)

Roof Vent Installation

Once you have assembled the roof vents you can now install them to your building. Prepare the ridge hinge (EV0314M) by running a bead of **silicone** along the back edge (diagrams 83 and 84).

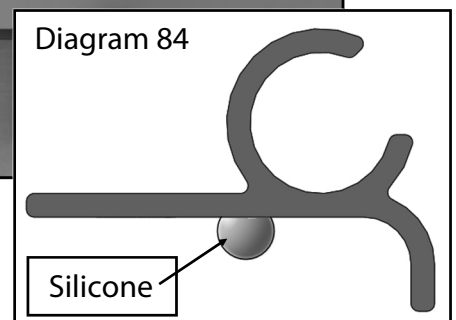
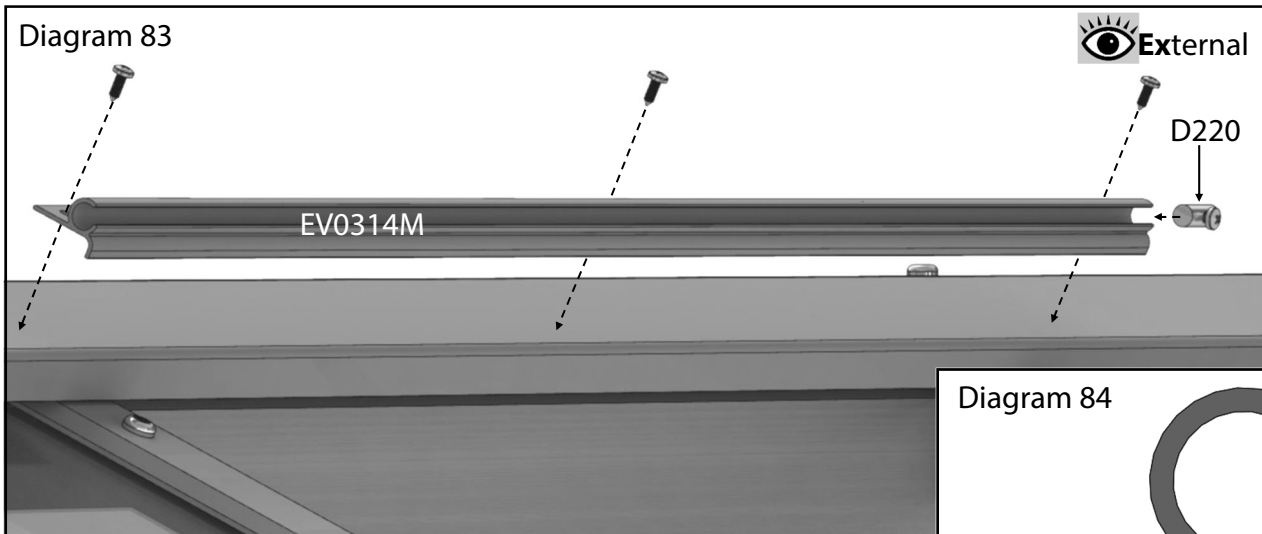

Then position this spaced equally over the opening in the roof. Use the 13mm self tapping screws (EV0329) to fix the hinge section to the ridge cap, the screws will bore their own hole into the aluminium as you screw. Secure one of the vent stops (D220) at one end of the ridge hinge channel.

Next slide the roof vent along the channel of the ridge hinge from one end and secure with another vent stop, diagram 85 and 86. You can now lower the vent until it rests on the roof bars.

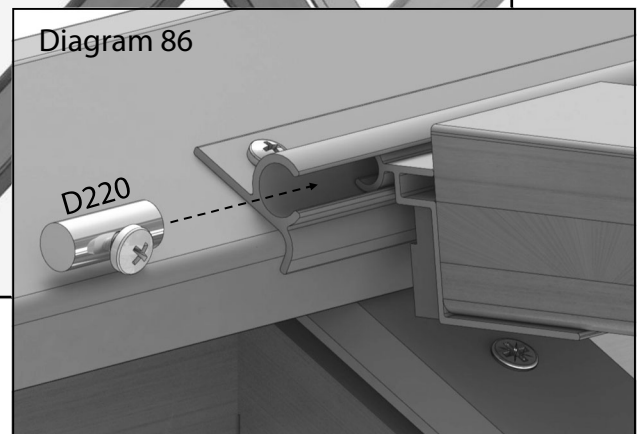
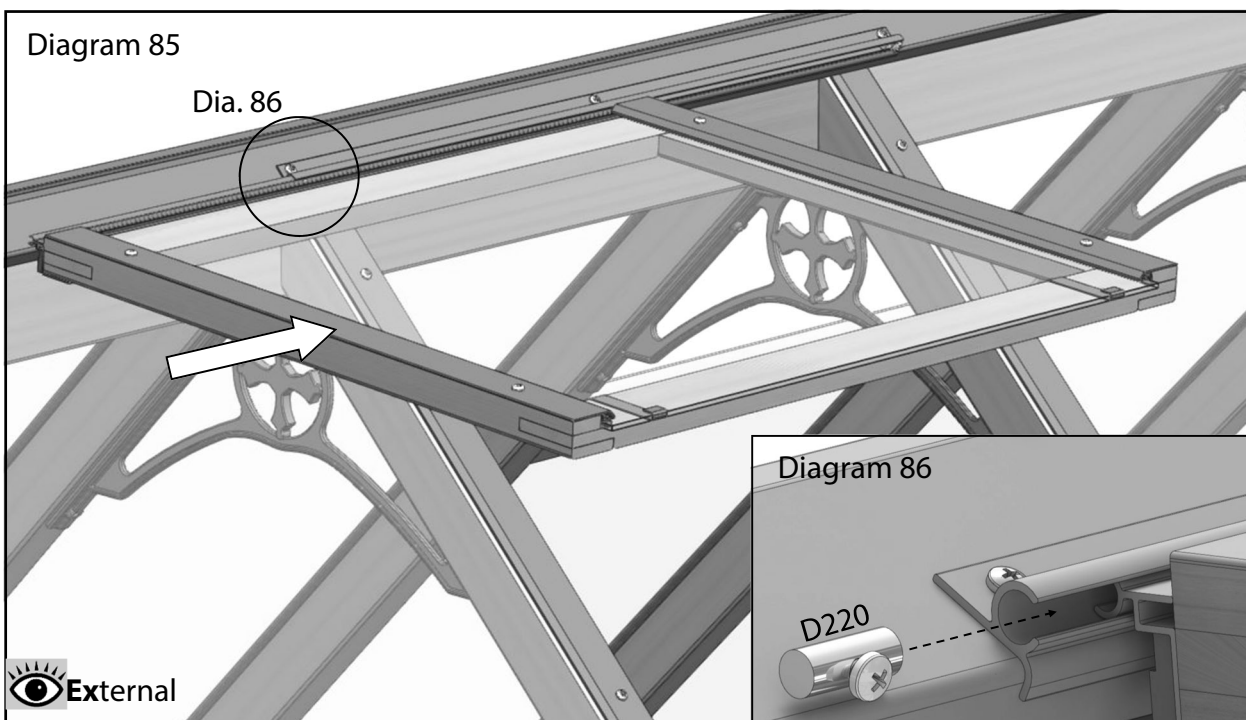

Roof Vent Installation

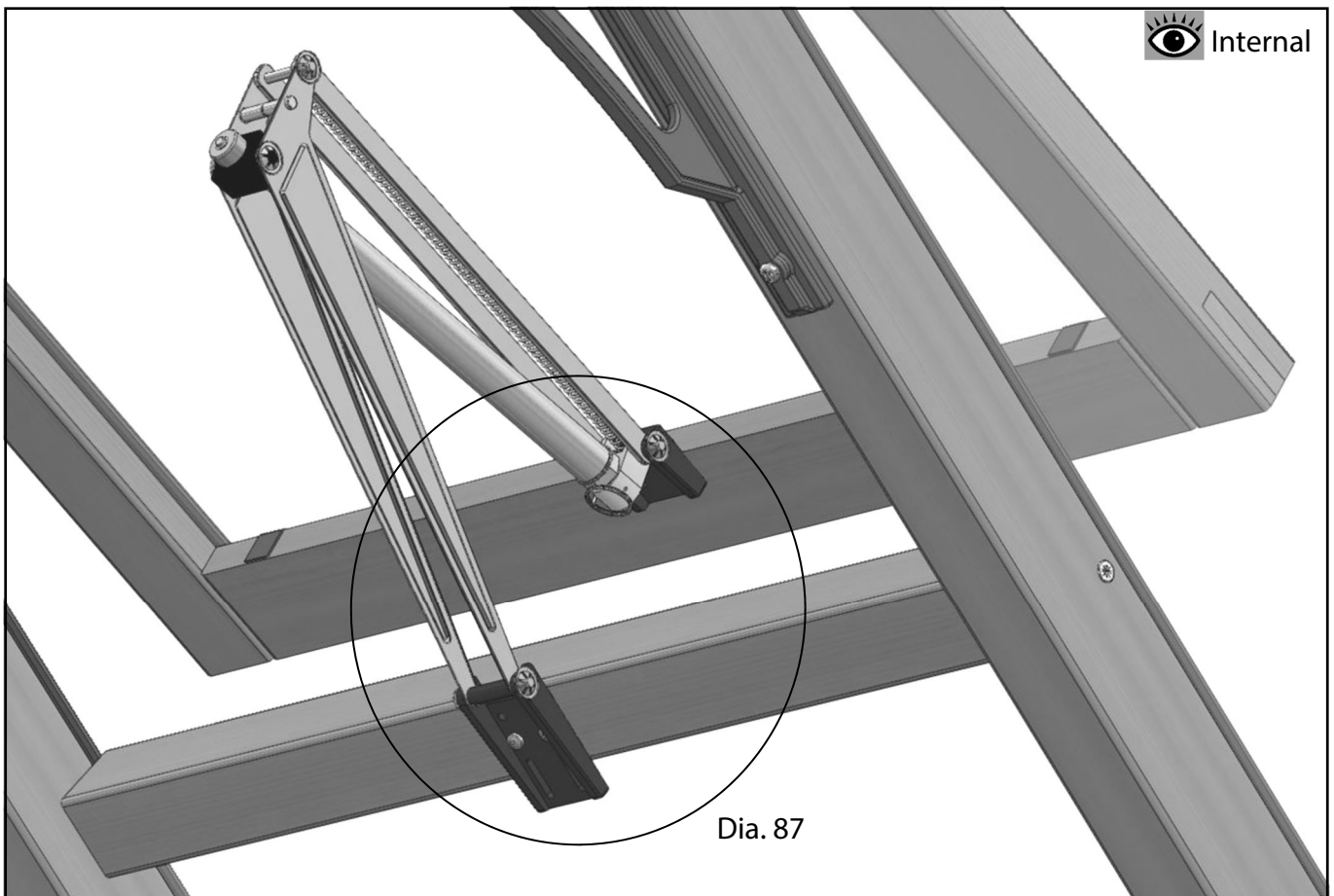

Now fit your autovents to the slam rail and to the bottom of the roof vents, diagram 87. Use 19mm screws to secure the top arm of the autovent to the roof vent, do this with the roof vent in the closed position so that you get the bracket in the correct position.

Adjust the position of the lower arm on the slam rail until the arms of the autovent are parallel with the roof as possible, then fix with 25mm screws.

NB. Disregard any fitting instructions in the autovent box and any extra plates or screws as these are for other greenhouses. However you should keep the leaflet as the operating instructions are on there.

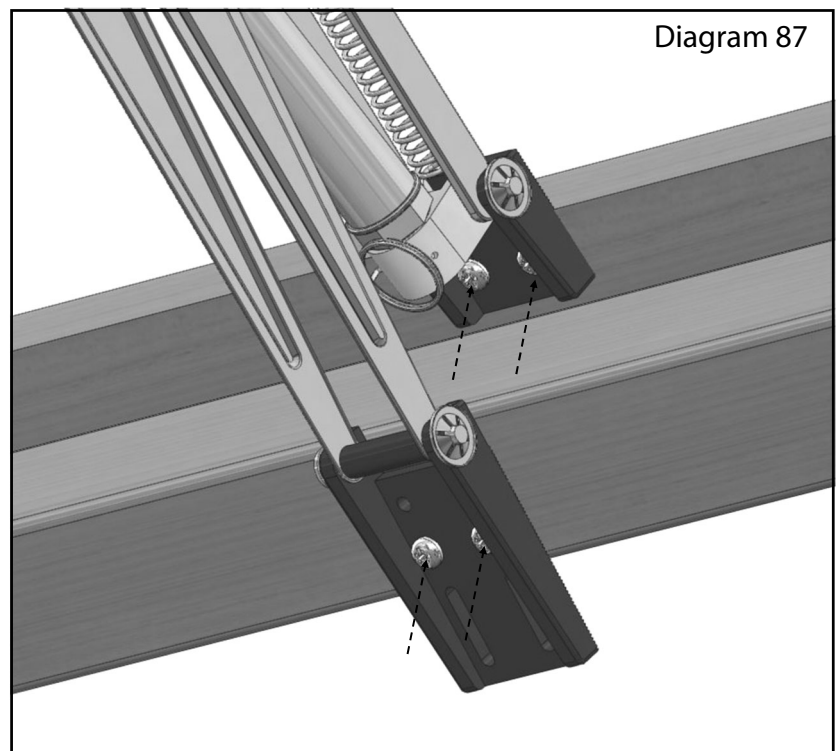

Optional Cresting

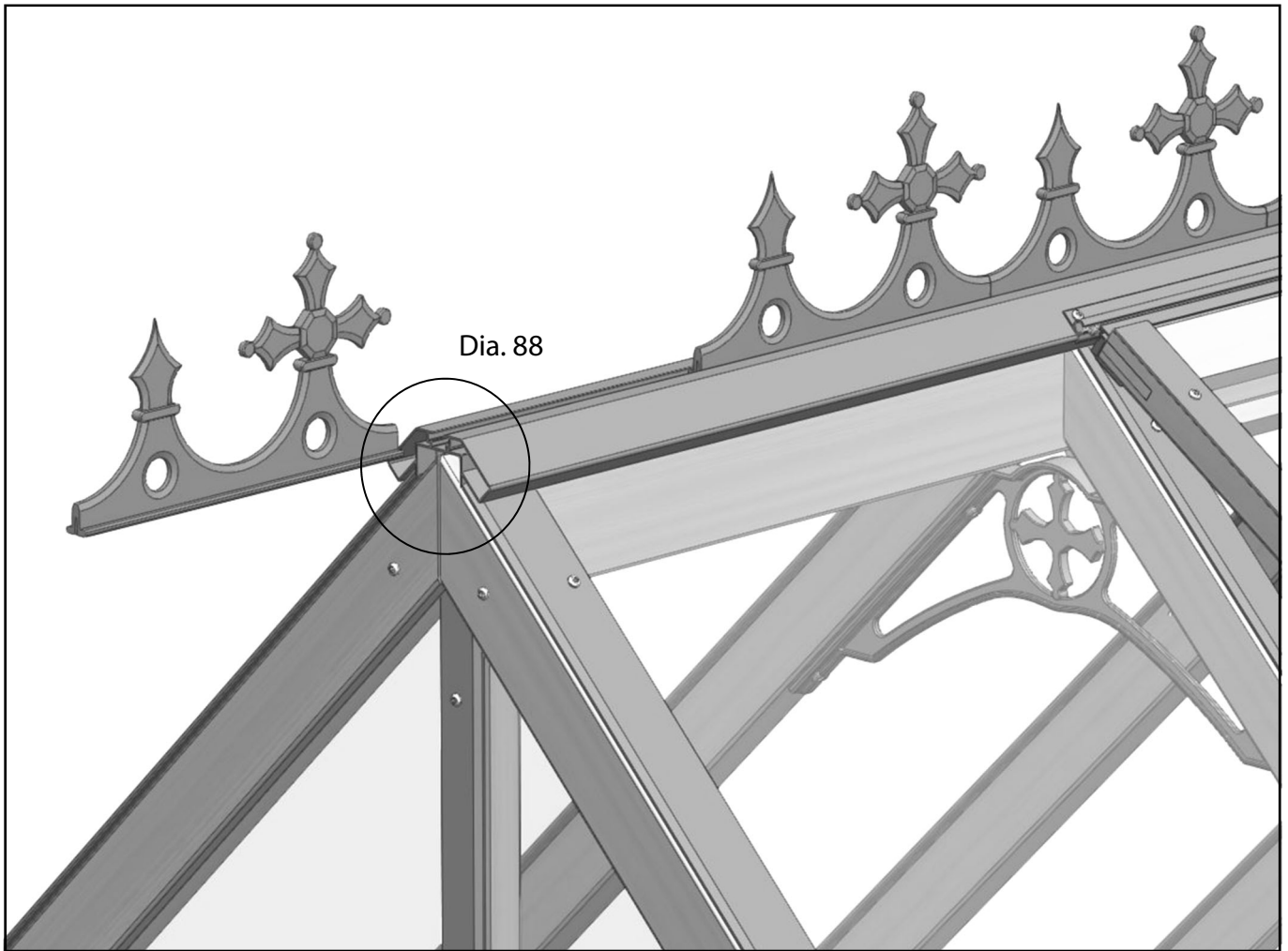

From one end of the building and from the front of your porch slide your cresting pieces along the channel in the ridge cover caps making sure they are in the correct orientation (diagram 88).

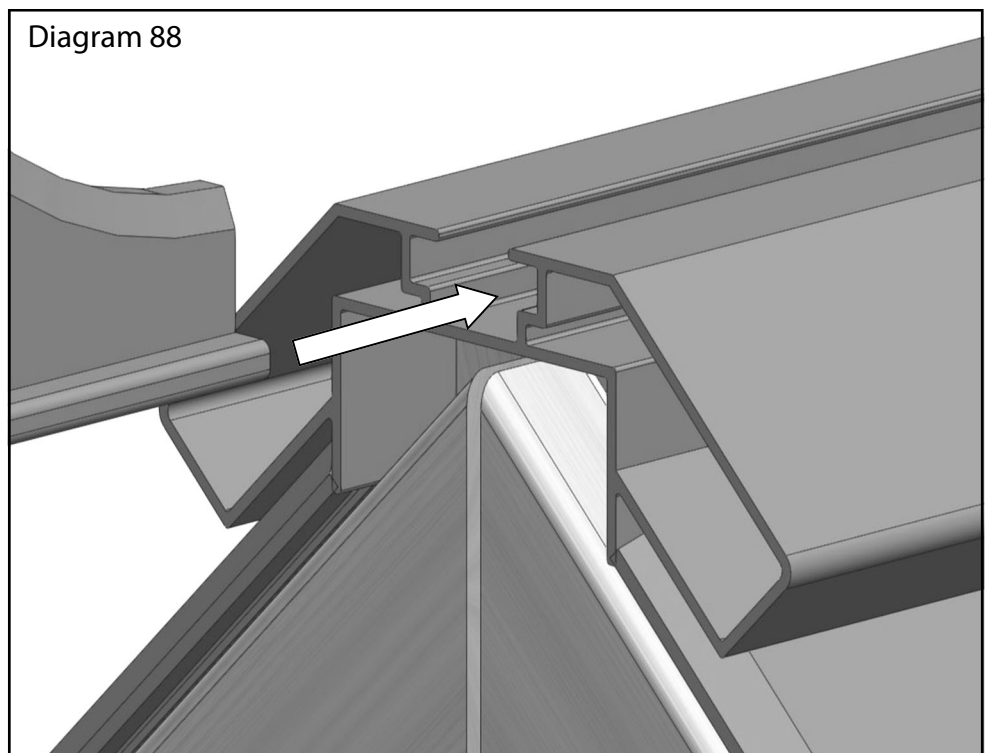

End cap and Finial

Diagram 89

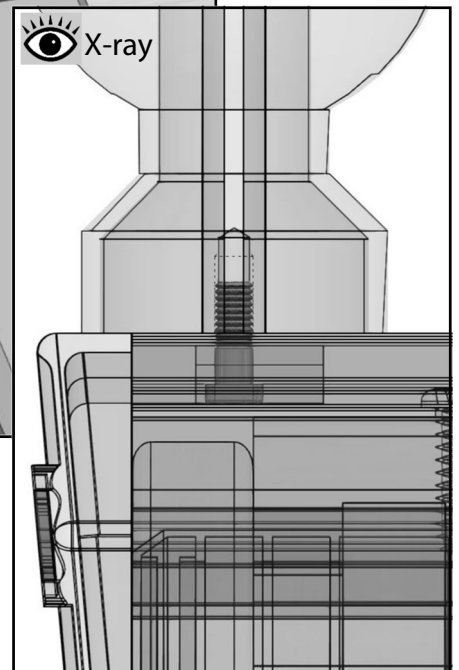
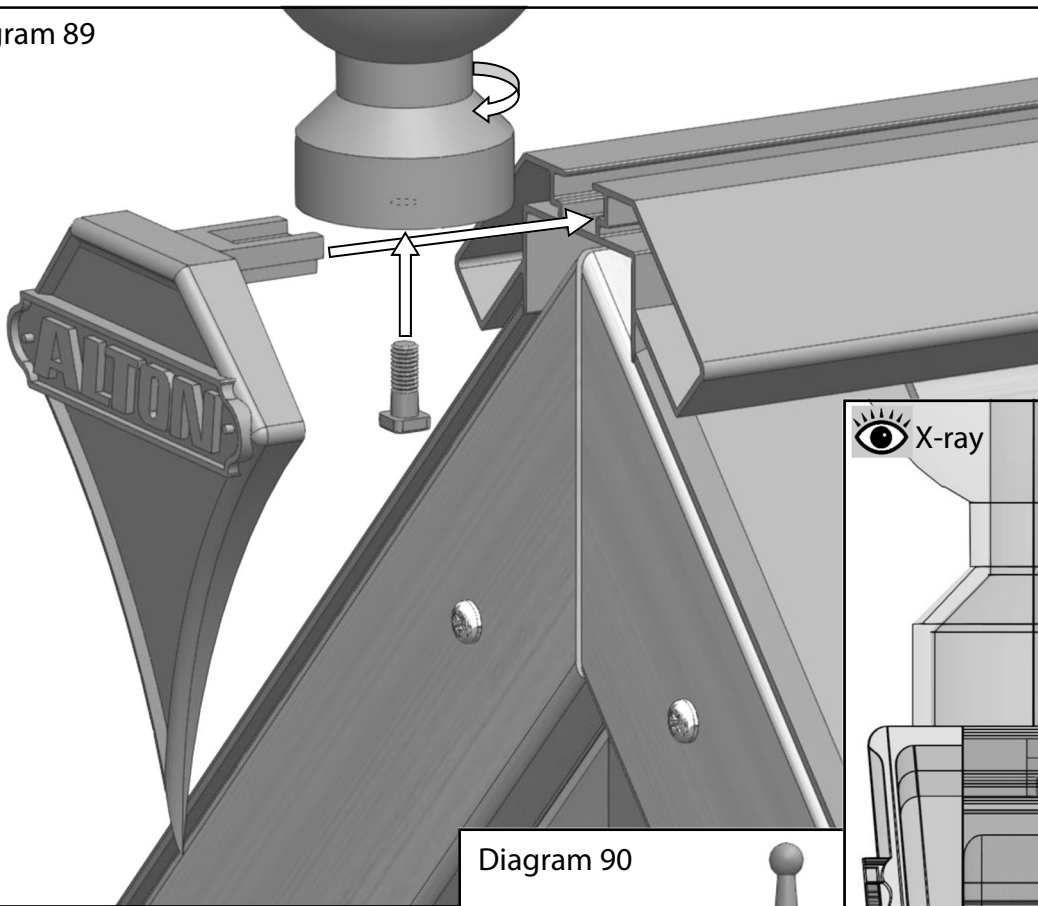
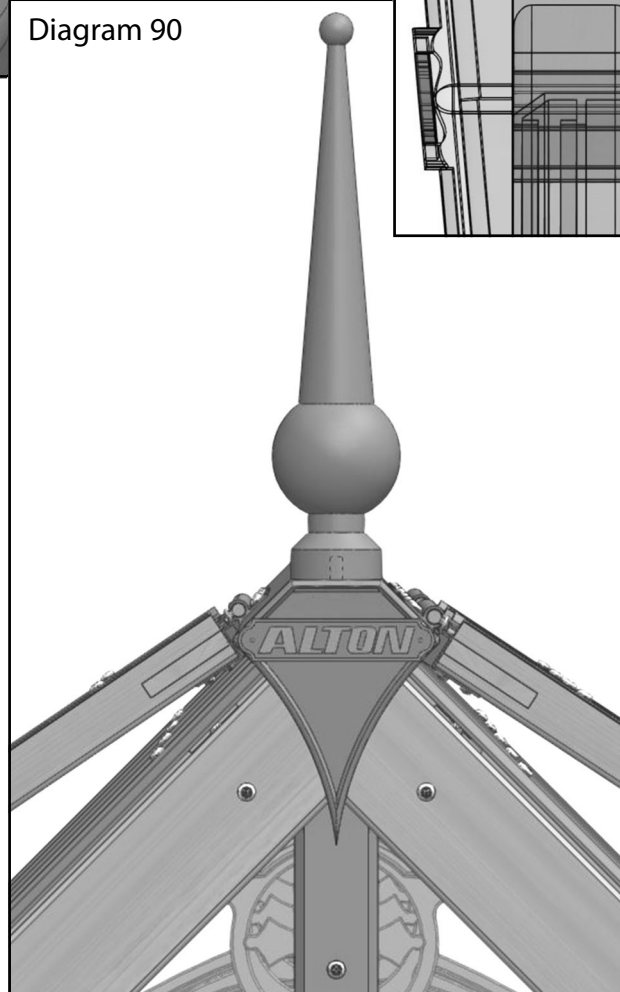

Diagram 90



The end cap and finial bolt together with a 22mm M6 bolt. The easiest way to attach this is to slide the end cap onto the end of the ridge cover cap, then slide the bolt on the end cap (the head should locate in the lower recess of the end cap), with the bolt in place you can then screw the finial down onto the bolt (diagrams 89 and 90).

Finish installation

When you are happy with the final position of your greenhouse and all the sides are vertical and square you can fix the greenhouse to the ground. Use brown rawl plugs, 50mm screws and a 7mm hammer drill to secure it through the base brackets previously attached (diagram 91).

Finally, check the door opens and closes well. Adjust if necessary then fix with another 4 x 50mm countersunk screws as shown below, diagram 92.

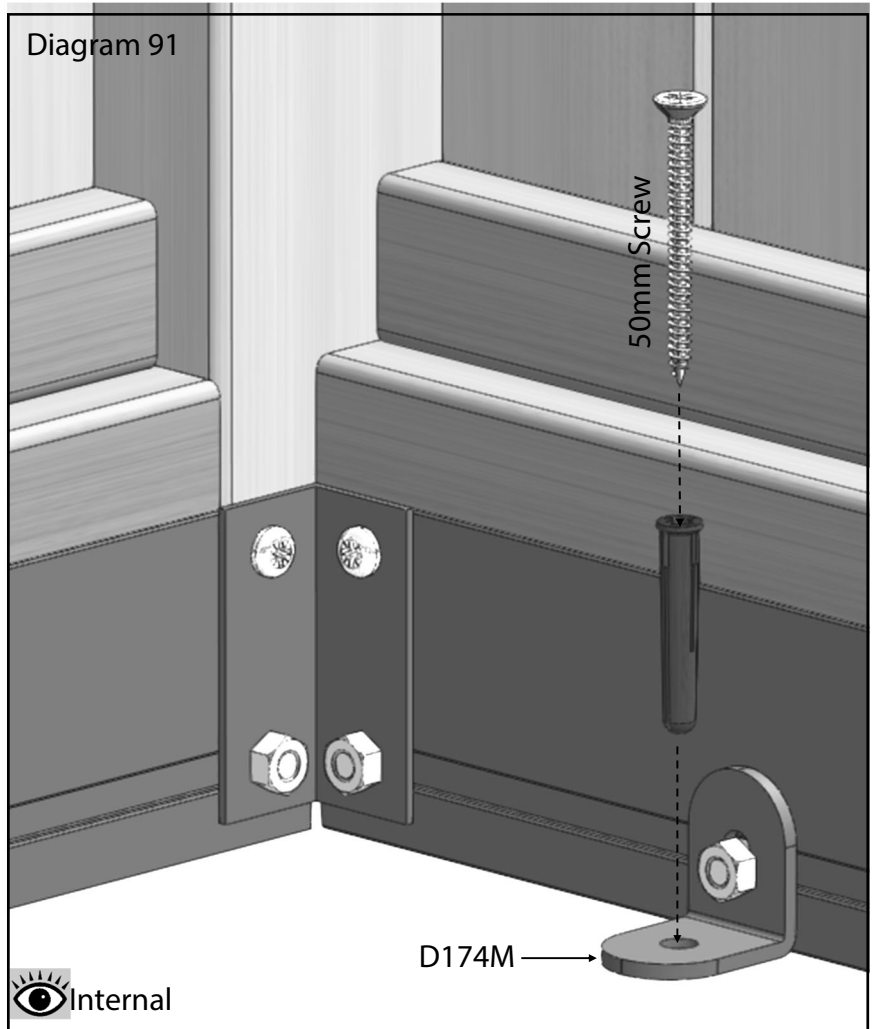
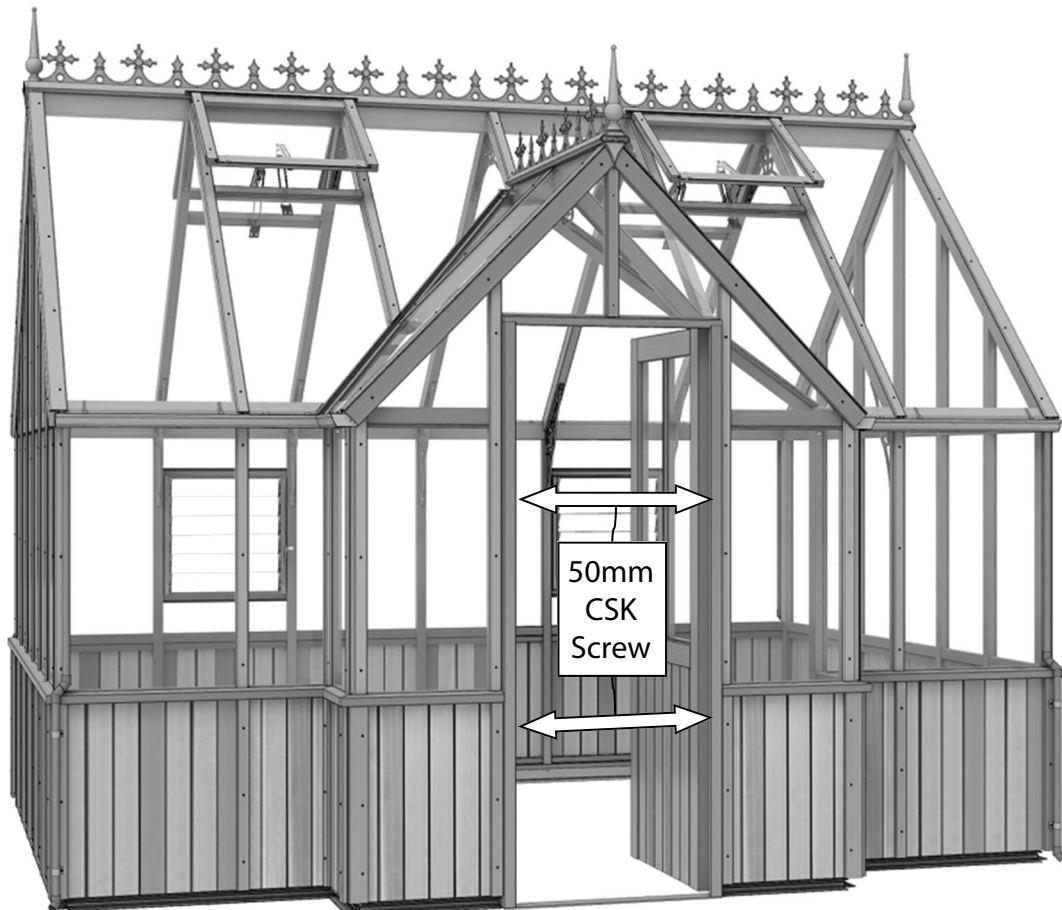

Diagram 92



Optional Auto Louvre Installation (part I)

Once the louvre is installed in the greenhouse you can replace the manual handle with the automatic unit.

First of all remove the screw to release the arm (diagram 93).

Next Remove the handle from the frame of the louvre (diagram 94).

Diagram 95 shows the parts you need to attach the auto opener.

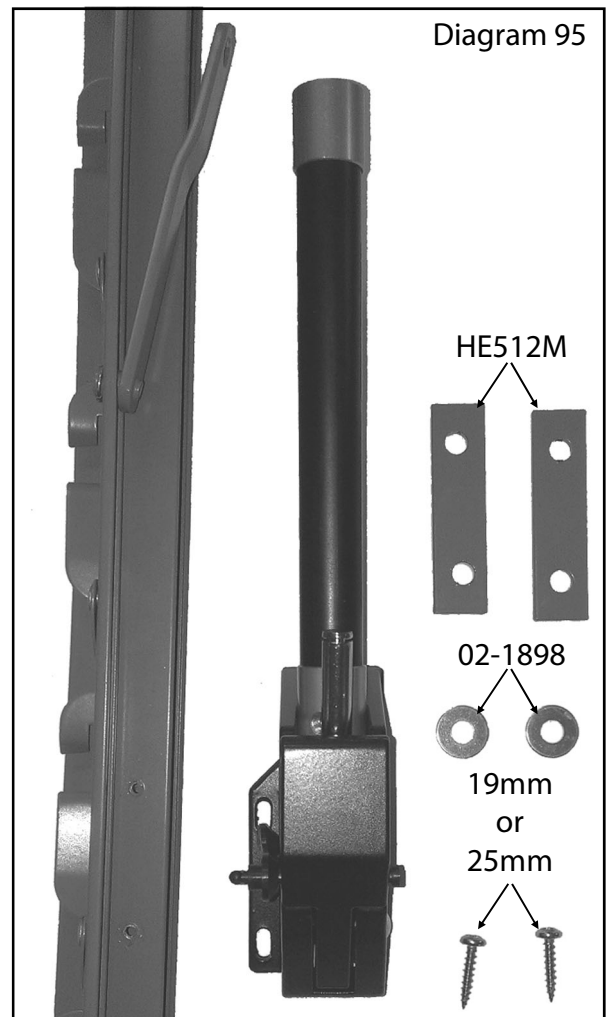
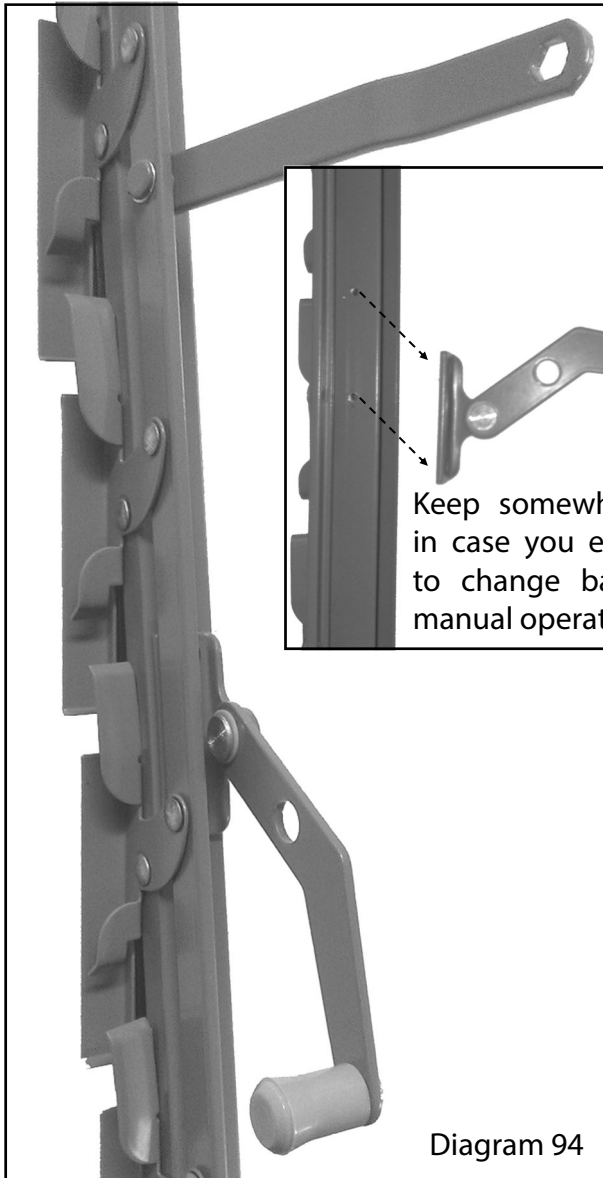
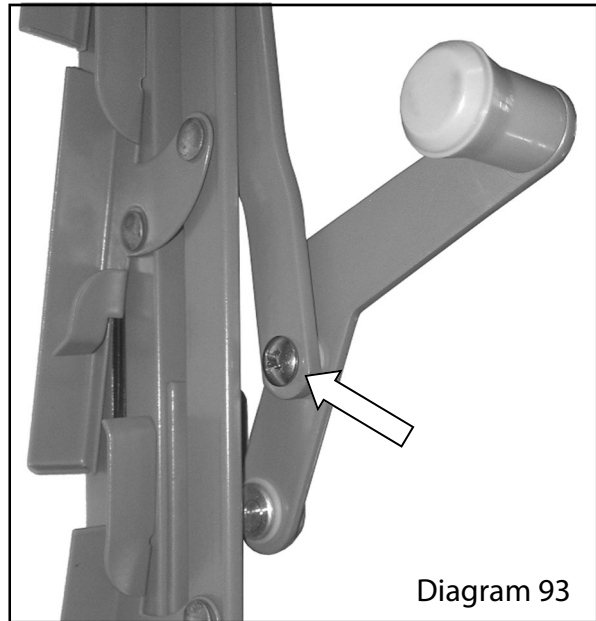

Optional Auto Louvre Installation (part 2)

Offer the opener up to the frame with the plates and washers and slide the louvre arm into position. This now gives you the correct location for the opener (diagram 96).

You now need to mark the frame and to drill two holes, use a 2.5mm drill bit for this. Once you have marked the frame remove the opener to drill the holes.

Now fix the opener to the frame using the 2 plates and 2 washers (diagram 97). You should have either 19mm or 25mm screws spare from the greenhouse frame for this. Once fixed in place attached the louvre arm to the opener and hold in place with the plastic pop-on cap (diagram 98).

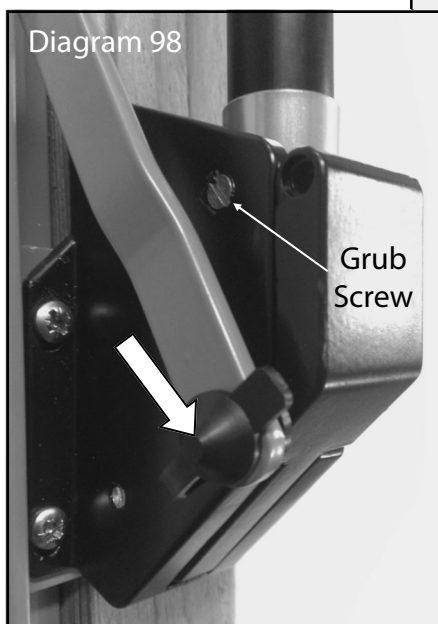
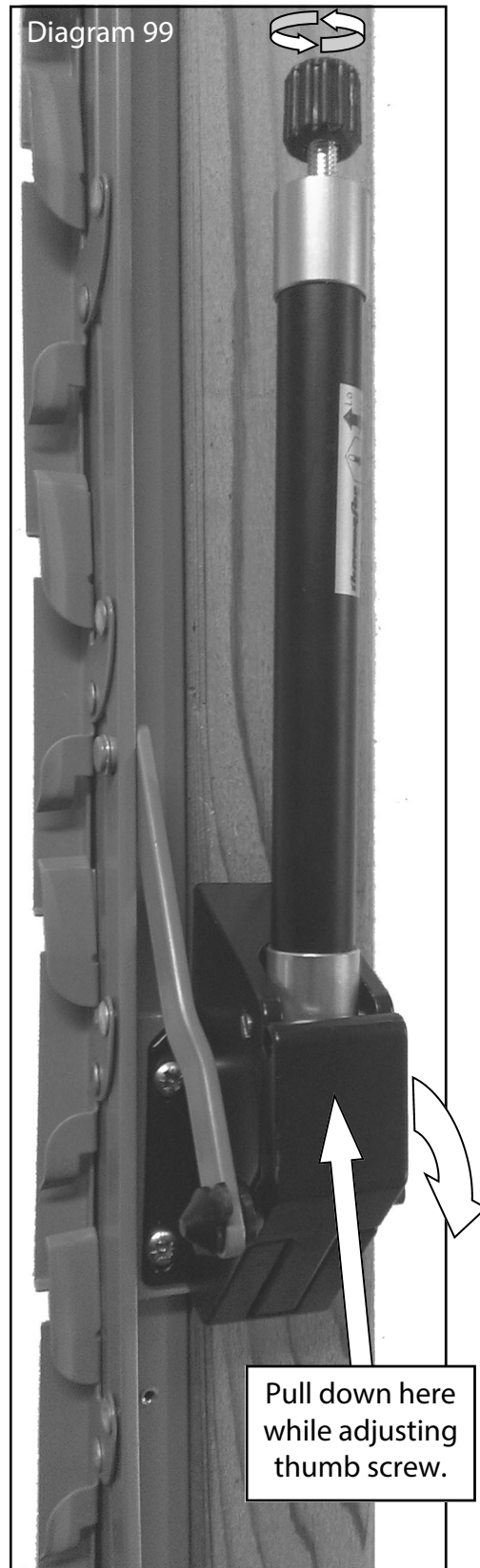
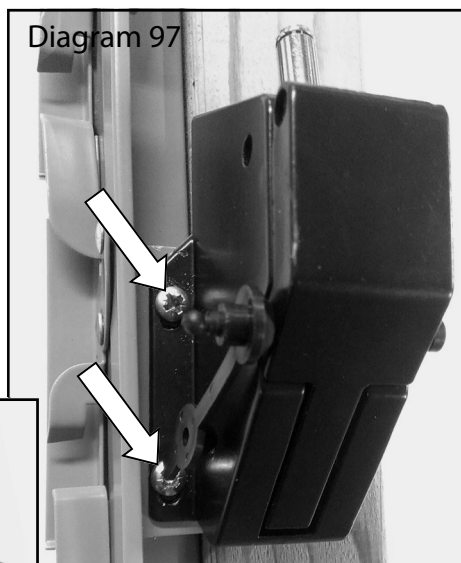
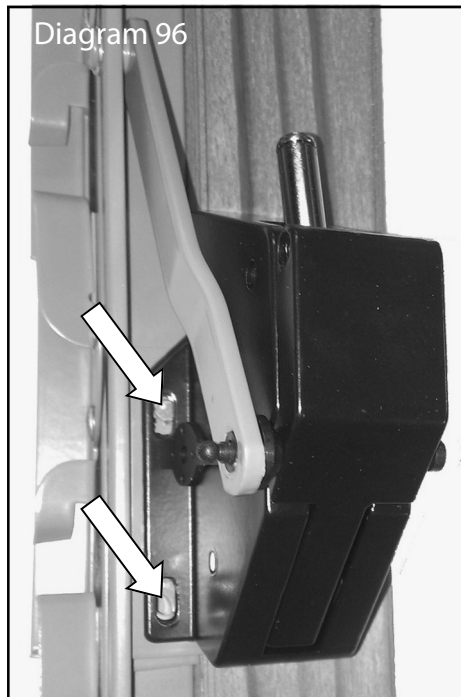

Now slide the cylinder onto the shaft attached to the body of the opener, secure this in place with 2 grub screws (diagram 98).

Finally fit the thumb screw to the end of the cylinder, adjust this to get the desired amount of ventilation (diagram 99).

Parts Lists

9x8 Porch Specific

EVPORCL8HB1	Evo Victorian with Porch Common Length 8ft Long **HB** - 1 of 2	Quantity
EV0016	Cill Side 8ft long EV0016 2476mm	1
EV0419	Eaves Bar 8ft long EV0419 2564mm	1
EV0438	Mid Rail Side 8ft EV0438 2564mm *HB*	1
EV0501	Glazing Bar Side EV0501 1588mm *HB*	3
EV0304M	ALU Side Base 8ft long EV0304 2474mm **MOSS**	1
EV0622M	ALU Vic Gutter 8ft long EV0622 2564mm **MOSS**	1
EVPORCL8HB2	Evo Victorian with Porch Common Length 8ft Long **HB** - 2 of 2	
EV0902	Porch Mid Rail 1ft Deep LH	1
EV0903	Porch Mid Rail 1ft Deep RH	1
EV0906	Porch Cill 1ft Deep	2
EV0908	Porch Eaves Rail 1ft Deep LH	1
EV0909	Porch Eaves Rail 1ft Deep RH	1
EV1163M	Porch Gutter 1ft deep LH **MOSS**	1
EV1164M	Porch Gutter 1ft deep RH **MOSS**	1
EV1169M	Porch Base 1ft deep LH **MOSS**	1
EV1170M	Porch Base 1ft deep RH **MOSS**	1
ROSEPS	Glass separators 4mm black	4

9x12 Porch Specific

EVPORCL12HB1	Evo Victorian with Porch Common Length 12ft Long **HB** - 1 of 2	Quantity
EV0018	Cill Side 12ft long EV0018 3736mm	1
EV0421	Eaves Bar 12ft long EV0421 3824mm	1
EV0440	Mid Rail Side 12ft EV0440 3824mm *HB*	1
EV0501	Glazing Bar Side EV0501 1588mm *HB*	7
EV0306M	ALU Side Base 12ft long EV0306 3734mm **MOSS**	1
EV0624M	ALU Vic Gutter 12ft long EV0624 3824mm **MOSS**	1
EVPORCL12HB2	Evo Victorian with Porch Common Length 12ft Long **HB** - 2 of 2	
EV0904	Porch Mid Rail 3ft Deep LH	1
EV0905	Porch Mid Rail 3ft Deep RH	1
EV0907	Porch Cill 3ft Deep	2
EV0910	Porch Eaves Rail 3ft Deep LH	1
EV0911	Porch Eaves Rail 3ft Deep RH	1
EV1165M	Porch Gutter 3ft deep LH **MOSS**	1
EV1166M	Porch Gutter 3ft deep RH **MOSS**	1
EV1171M	Porch Base 3ft deep LH **MOSS**	1
EV1172M	Porch Base 3ft deep RH **MOSS**	1
ROSEPS	Glass separators 4mm black	4

End Gables x 2 required

EVCHGABPE	Evo Victorian 8ft wide Plain Gable **HB**	Quantity
EV0501	Glazing Bar Side EV0501 1588mm *HB*	3
EV0502	Glazing Bar Side Corner R EV0502 1650mm *HB*	1
EV0503	Glazing Bar Side Corner L EV0503 1650mm *HB*	1
EV0405	Cill Rear Gable 8ft wide EV0405 2569mm	1
EV0409	Purling Gable 8ft wide R EV0409 857mm	1
EV0413	Purling Rear Gable EV413 850mm	1
EV0415	Purling Gable 8ft wide L EV0415 857mm	1
EV0433	Mid Rail Rear 8ft wide EV0433 2707mm *HB*	1
EV0506	Glazing Bar Gable 8ft wide R EV0506 2582mm *HB*	1
EV0507	Glazing Bar Gable 8ft wide L EV0507 2582mm *HB*	1
EV0461	Glazing Bar Above Middle Purling 8ft wide EV0461 1275mm	1
EV0465	Glazing Bar Above Purling 8ft wide R EV0465 518mm	1
EV0466	Glazing Bar Above Purling 8ft wide L EV0466 518mm	1
EV0482	Glazing Bar Roof Corner 8ft wide R EV0482 1853mm	1
EV0483	Glazing Bar Roof Corner 8ft wide L EV0483 1853mm	1
EV0523	Roof Corner Cloaking 8ft wide R EV0523 1891mm	1
EV0524	Roof Corner Cloaking 8ft wide L EV0524 1891mm	1
EV0613M	ALU Vic Rear Base 8ft wide EV0613 2554mm **MOSS**	1
ROSEPS	Glass separators 4mm black	6

Parts Lists

9x8 House Specific

EVPORHOU88P6B1	Evo Victorian with Porch 8x8 House Box - 1 of 2	Quantity
EV0445	Ridge Bar 8ft long EV0445 2564mm	1
EV0477	Glazing Bar Roof 8ft wide EV0477 1853mm	3
EV0773	Cripple Common Glazing Bar 6ft wide with 8ft deep	1
EV0778	Porch Valley Jack Glazing Bar 8ft LH	1
EV0779	Porch Valley Jack Glazing Bar 8ft RH	1
EV0628M	ALU Vic Ridge Cap 8ft long EV0628 2602mm **MOSS**	1
D211	Grey Downpipe Length 1625mm	2
EVPORHOU88P6B2	Evo Victorian with Porch 8x8 House Box - 2 of 2	
EV0313M	Glass Stop EV0313 **MOSS**	12
EV0537M	Alton Eaves Bracing EV0537 **MOSS**	3
EV0538M	Alton Ridge Bracing EV0538 **MOSS**	3
EV1156M	Porch Valley Ridge Bracket **MOSS**	1
EVPACVIC	Victorian Component Pack	1
EVPACVENT	Vent pack bundle for Evo	2
EVSMA01	Smalls Pack No 01 for Evolution	1
EVSMAVIC01	Smalls Pack No 01 for Victorian	1
ROSEPS	Glass separators 4mm black	2
INS	***GREENHOUSE INSTRUCTIONS***	1

9x12 House Specific

EVPORHOU812P6B1	Evo Victorian with Porch 8x12 House Box - 1 of 2	Quantity
EV0447	Ridge Bar 12ft long EV0447 3824mm	1
EV0477	Glazing Bar Roof 8ft wide EV0477 1853mm	7
EV0773	Cripple Common Glazing Bar 6ft wide with 8ft deep	1
EV0778	Porch Valley Jack Glazing Bar 8ft LH	1
EV0779	Porch Valley Jack Glazing Bar 8ft RH	1
EV0630M	ALU Vic Ridge Cap 12ft long EV0630 3862mm **MOSS**	1
D211	Grey Downpipe Length 1625mm	2
EVPORHOU812P6B2	Evo Victorian with Porch 8x12 House Box - 2 of 2	
EV0313M	Glass Stop EV0313 **MOSS**	20
EV0537M	Alton Eaves Bracing EV0537 **MOSS**	7
EV0538M	Alton Ridge Bracing EV0538 **MOSS**	5
EV1156M	Porch Valley Ridge Bracket **MOSS**	1
EVPACVIC	Victorian Component Pack	1
EVPACVENT	Vent pack bundle for Evo	4
EVSMA01	Smalls Pack No 01 for Evolution	1
EVSMA02	Smalls Pack No 02 for Evolution	1
EVSMAVIC01	Smalls Pack No 01 for Victorian	1
ROSEPS	Glass separators 4mm black	2
INS	***GREENHOUSE INSTRUCTIONS***	1

1' Deep Porch

EVPOR61HB1	Evo Victorian 6ft wide x 1ft deep Porch **HB** - 1 of 2	Quantity
EV0502	Glazing Bar Side Corner R EV0502 1650mm *HB*	1
EV0503	Glazing Bar Side Corner L EV0503 1650mm *HB*	1
EV0504	Glazing Bar Gable R 6ft wide EV0504 2208mm *HB*	1
EV0505	Glazing Bar Gable L 6ft wide EV0505 2208mm *HB*	1
EV0770	Vic Porch Ridge Bar_1ft Porch 1259mm	1
EV0776	Porch Valley Jack Glazing Bar 6ft LH 840mm	1
EV0777	Porch Valley Jack Glazing Bar 6ft RH 840mm	1
EV0788	Porch Valley Bar 6ft wide with 6ft/8ft/10ft deep 1593mm	2
EV0791	Glazing Bar Porch Internal Corner Plant 1640mm *HB*	2
EV0794	Glazing Bar Porch Internal Corner LH 1648mm *HB*	1
EV0795	Glazing Bar Porch Internal Corner RH 1648mm *HB*	1
EV1161M	Porch Valley Gutter_6ft wide 1610mm **MOSS**	2
EV1174M	Porch Ridge Cap 1ft deep 1276mm **MOSS**	1

Parts Lists

1' Deep Porch Specific

EVPOR61HB2	Evo Victorian 6ft wide x 1ft deep Porch **HB** - 2 of 2	Quantity
EV0005	Cill Front Gable 5ft wide EV0005 546mm	2
EV0408	Purling Gable 6ft wide R EV0408 480mm	1
EV0414	Purling Gable 6ft wide L EV0414 480mm	1
EV0424	Mid Rail Front 6ft wide R EV0424 576mm *HB*	1
EV0425	Mid Rail Front 6ft wide L EV0425 576mm *HB*	1
EV0471	Glazing Bar Above Door 6ft wide EV0471 561mm	1
EV0480	Glazing Bar Roof Corner R 6ft wide EV0480 1324mm	1
EV0481	Glazing Bar Roof Corner L 6ft wide EV0481 1324mm	1
EV0521	Roof Corner Cloaking R 6ft wide EV0521 1362mm	1
EV0522	Roof Corner Cloaking L 6ft wide EV0522 1362mm	1
EV0902	Porch Mid Rail 1ft Deep LH 329mm	1
EV0903	Porch Mid Rail 1ft Deep RH 329mm	1
EV0906	Porch Cill 1ft Deep 286mm	2
EV0908	Porch Eaves Rail 1ft Deep LH 373mm	1
EV0909	Porch Eaves Rail 1ft Deep RH 373mm	1
EV0293M	ALU Front Base 5ft wide EV0293 500mm **MOSS**	2
EV0538M	Alton Ridge Bracing EV0538 **MOSS**	1
EV1163M	Porch Gutter 1ft deep LH 332mm **MOSS**	1
EV1164M	Porch Gutter 1ft deep RH 332mm **MOSS**	1
EV1169M	Porch Base 1ft deep LH 330mm **MOSS**	1
EV1170M	Porch Base 1ft deep RH 330mm **MOSS**	1
D211	Grey Downpipe Length 1625mm	2
EVPACPOR	Evo Victorian Porch Component Pack	1
EVSMAPOR1	Evo Victorian Porch Smalls Pack	1

Cedar Capping

	EVPOR61CAPCHB	Evo Victorian Porch Cedar Capping 6ft x 1ft **HB**	Quantity
Gable	EV0556	Cedar Capping Side Corner R EV0556 946mm *HB/DW*	1
	EV0557	Cedar Capping Side Corner L EV0557 946mm *HB/DW*	1
	EV0564	Cedar Capping Gable 6ft wide R EV0564 1422mm *HB/DW*	1
	EV0565	Cedar Capping Gable 6ft wide L EV0565 1422mm *HB/DW*	1
	EV0569	Cedar Capping Above Door 6ft wide EV0570 528mm	1
Side	EV0555	Cedar Capping Side EV0555 910mm *HB/DW*	2
	EV1180M	ALU Vic Porch Internal Corner Side Capping 909mm **MOSS** *HB/DW*	2
Roof	EV0593	Cedar Capping Roof Corner 6ft wide EV0593 1328mm	2
	EV1194	Porch Valley Jack Capping 6ft LH 849mm	1
	EV1195	Porch Valley Jack Capping 6ft RH 849mm	1
Panels	EV0598	Cedar Capping for HB Panel EV0598 668mm	4
	EV0599	Cedar Capping for HB Panel Corner EV0599 668mm	2
	EV1200	HB Porch Panel Capping	2
	02-1356	Clear Silicone	1
	EV0227	Glazing PVC 10m (m700) 1729D10GP coil	1

Cedar Capping

		Evo Victorian with Porch Cedar Capping **HB**	EVPOR88C APCHB	EVPOR812C APCHB
Gable	EV0556	Cedar Capping Side Corner R EV0556 946mm *HB/DW*	2	
	EV0557	Cedar Capping Side Corner L EV0557 946mm *HB/DW*	2	
	EV0558	Cedar Capping Gable 8ft wide 1st R EV0558 1372mm *HB/DW*	2	
	EV0559	Cedar Capping Gable 8ft wide 1st L EV0559 1372mm *HB/DW*	2	
	EV0560	Cedar Capping Gable 8ft wide 2nd R EV0560 1796mm *HB/DW*	2	
	EV0561	Cedar Capping Gable 8ft wide 2nd L EV0561 1796mm *HB/DW*	2	
	EV0567	Cedar Capping Mid 8ft wide EV0567 2200mm *HB/DW*	2	
Side	EV0555	Cedar Capping Side EV0555 909mm *HB/DW*	7	11
Roof	EV0151	Cedar Capping Roof Vent EV0151 596mm	4	8
	EV0589	Cedar Capping Roof 8ft wide EV0589 1862mm	3	7
	EV0594	Cedar Capping Roof Corner 8ft wide EV0594 1862mm		4
	EV1191	Cedar Above Porch Capping 538mm		1
	EV1196	Porch Valley Jack Capping 8ft LH		1
	EV1197	Porch Valley Jack Capping 8ft RH		1
Panels	EV0598	Cedar Capping for HB Panel EV0598 668mm	17	21
	EV0599	Cedar Capping for HB Panel Corner EV0599 668mm		4
	02-1356	Clear Silicone	3	4

Parts Lists

Aluminium Capping

EVPOR61CAPAHB		Evo Victorian Porch Alu Capping 6ft x 1ft **HB**	Quantity
Gable	EV0656M	ALU Vic Capping Side Corner R EV0656 946mm **MOSS** *HB/DW*	1
	EV0657M	ALU Vic Capping Side Corner L EV0657 946mm **MOSS** *HB/DW*	1
	EV0664M	ALU Vic Capping Gable 6ft wide R EV0664 1422mm **MOSS** *HB/DW*	1
	EV0665M	ALU Vic Capping Gable 6ft wide L EV0665 1422mm **MOSS** *HB/DW*	1
	EV0669M	ALU Vic Capping Above Door 6ft wide EV0669 528mm **MOSS**	1
Side	EV0655M	ALU Vic Capping Side EV0655 909mm **MOSS** *HB/DW*	2
	EV1180M	ALU Vic Porch Internal Corner Side Capping 909mm **MOSS** *HB/DW*	2
Roof	EV0693M	ALU Vic Capping Roof Corner 6ft wide EV0693 1328mm **MOSS**	2
	EV1184M	Porch Valley Jack Capping 6ft LH_Alu 849mm **MOSS**	1
	EV1185M	Porch Valley Jack Capping 6ft RH_Alu 849mm **MOSS**	1
Panels	EV0598	Cedar Capping for HB Panel EV0598 668mm	4
	EV0599	Cedar Capping for HB Panel Corner EV0599 668mm	2
	EV1200	HB Porch Panel Capping	2
Rubber	EV0227	Glazing PVC 10m (m700) 1729D10GP coil	3

Aluminium Capping

		Evo Victorian with Porch Alu Capping **HB**	EVPOR88C APAHB	EVPOR812C APAHB
Gable	EV0656M	ALU Vic Capping Side Corner R EV0656 946mm **MOSS** *HB/DW*	2	
	EV0657M	ALU Vic Capping Side Corner L EV0657 946mm **MOSS** *HB/DW*	2	
	EV0658M	ALU Vic Capping Gable 8ft wide 1st R EV0658 1372mm **MOSS** *HB/DW*	2	
	EV0659M	ALU Vic Capping Gable 8ft wide 1st L EV0659 1372mm **MOSS** *HB/DW*	2	
	EV0660M	ALU Vic Capping Gable 8ft wide 2nd R EV0660 1796mm **MOSS** *HB/DW*	2	
	EV0661M	ALU Vic Capping Gable 8ft wide 2nd L EV0661 1796mm **MOSS** *HB/DW*	2	
	EV0667M	ALU Vic Capping Mid 8ft wide EV0667 2200mm **MOSS** *HB/DW*	2	
Side	EV0655M	ALU Vic Capping Side EV0655 909mm **MOSS** *HB/DW*	7	11
Roof	EV0251M	ALU Roof Vent Capping EV0251 596mm **MOSS**	4	8
	EV0689M	ALU Vic Capping Roof 8ft wide EV0689 1862mm **MOSS**	3	7
	EV0694M	ALU Vic Capping Roof Corner 8ft wide EV0694 1862mm **MOSS**		4
	EV1181M	Alu Cripple Common Capping 8' deep alu 538mm **MOSS**		1
	EV1186M	Porch Valley Jack Capping 8ft LH_Alu 1376mm **MOSS**		1
EV1187M	Porch Valley Jack Capping 8ft RH_Alu 1376mm **MOSS**		1	
Panels	EV0598	Cedar Capping for HB Panel EV0598 668mm	17	21
	EV0599	Cedar Capping for HB Panel Corner EV0599 668mm		4
Rubber	EV0227	Glazing PVC 10m (m700) 1729D10GP coil	-	3
	EV0231	Glazing PVC 100m (m700) 1729D10GP coil	1	1



Alton Greenhouses, TGP Ltd, Blythe Park, Cresswell, Stoke-on-Trent, ST11 9RD

Telephone: 01782 385 409 www.Altongreenhouses.co.uk sales@altongreenhouses.co.uk